

2421 Fourth Street
Berkeley, California 94710
510.649.1414
www.TrachtenbergArch.com



**1201
SAN PABLO
MIXED-USE**

Berkeley, CA 94706

- 03.11.2021 SB-330 PRE-APPLICATION
- 04.29.2021 ZONING APPLICATION
- 07.13.2021 ZONING COMPLETENESS
- 08.30.2021 ZONING COMPLETENESS

ALL DRAWINGS AND WRITTEN MATERIAL APPEARING
HEREIN CONSTITUTE ORIGINAL AND UNPUBLISHED
WORK OF THE ARCHITECT AND MAY NOT BE
DUPLICATED, USED OR DISCLOSED WITHOUT WRITTEN
CONSENT OF TRACHTENBERG ARCHITECTS.

JOB: 1928

SHEET:
**BUILDING
ELEVATIONS**

A3.3



STEEL EAVE,
PTD.

METAL PANEL,
PTD.

METAL INFILL PANEL

INTEGRAL COLOR STUCCO
WITH HARD TROWEL FINISH

CORTEN STEEL
PANELS

ALUMINUM WINDOW
PANELS

T.O. PARAPET

ROOF

6TH FLOOR

5TH FLOOR

4TH FLOOR

3RD FLOOR

2ND FLOOR

HARRISON ST

AVG GROUND
FLOOR

WOOD FENCE

1

EAST ELEVATION

3/32" = 1'-0" @ 11X17 3/16" = 1'-0" @ 24X36



2421 Fourth Street
Berkeley, California 94710
510.649.1414
www.TrachtenbergArch.com



**1201
SAN PABLO
MIXED-USE**

Berkeley, CA 94706

- 03.11.2021 SB-330 PRE-APPLICATION
- 04.29.2021 ZONING APPLICATION
- 07.13.2021 ZONING COMPLETENESS
- 08.30.2021 ZONING COMPLETENESS

ALL DRAWINGS AND WRITTEN MATERIAL APPEARING
HEREIN CONSTITUTE ORIGINAL AND UNPUBLISHED
WORK OF THE ARCHITECT AND MAY NOT BE
DUPLICATED, USED OR DISCLOSED WITHOUT WRITTEN
CONSENT OF TRACHTENBERG ARCHITECTS.

JOB: 1928

SHEET:
**BUILDING
ELEVATIONS**

A3.4



CAST IN PLACE CONCRETE

1 SOUTH ELEVATION
3/32" = 1'-0" @ 11X17 3/16" = 1'-0" @ 24X36 0 4 8 16

2421 Fourth Street
Berkeley, California 94710
510.649.1414
www.TrachtenbergArch.com



**1201
SAN PABLO
MIXED-USE**

Berkeley, CA 94706

- 03.11.2021 SB-330 PRE-APPLICATION
- 04.29.2021 ZONING APPLICATION
- 07.13.2021 ZONING COMPLETENESS
- 08.30.2021 ZONING COMPLETENESS

ALL DRAWINGS AND WRITTEN MATERIAL APPEARING
HEREIN CONSTITUTE ORIGINAL AND UNPUBLISHED
WORK OF THE ARCHITECT AND MAY NOT BE
DUPLICATED, USED OR DISCLOSED WITHOUT WRITTEN
CONSENT OF TRACHTENBERG ARCHITECTS.

JOB: 1928

SHEET:

STREET STRIP
ELEVATIONS

A3.5



2

STREET STRIP ELEVATION @ HARRISON ST.

1/32" = 1'-0" @ 11X17 1/16" = 1'-0" @ 24X36

0 4 8 16 32



1

STREET STRIP ELEVATION @ SAN PABLO AVE.

1/32" = 1'-0" @ 11X17 1/16" = 1'-0" @ 24X36

0 4 8 16 32

2421 Fourth Street
Berkeley, California 94710
510.649.1414
www.TrachtenbergArch.com



**1201
SAN PABLO
MIXED-USE**

Berkeley, CA 94706

- 03.11.2021 SB-330 PRE-APPLICATION
- 04.29.2021 ZONING APPLICATION
- 07.13.2021 ZONING COMPLETENESS
- 08.30.2021 ZONING COMPLETENESS

ALL DRAWINGS AND WRITTEN MATERIAL APPEARING
HEREIN CONSTITUTE ORIGINAL AND UNPUBLISHED
WORK OF THE ARCHITECT AND MAY NOT BE
DUPLICATED, USED OR DISCLOSED WITHOUT WRITTEN
CONSENT OF TRACHTENBERG ARCHITECTS.

JOB: 1928

SHEET:

PERSPECTIVE
VIEWS

A3.6

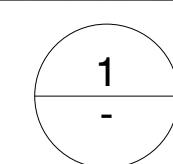

VIEW ALONG SAN PABLO - LOOKING SOUTH

2421 Fourth Street
Berkeley, California 94710
510.649.1414
www.TrachtenbergArch.com



**1201
SAN PABLO
MIXED-USE**

Berkeley, CA 94706

- 03.11.2021 SB-330 PRE-APPLICATION
- 04.29.2021 ZONING APPLICATION
- 07.13.2021 ZONING COMPLETENESS
- 08.30.2021 ZONING COMPLETENESS

ALL DRAWINGS AND WRITTEN MATERIAL APPEARING
HEREIN CONSTITUTE ORIGINAL AND UNPUBLISHED
WORK OF THE ARCHITECT AND MAY NOT BE
DUPLICATED, USED OR DISCLOSED WITHOUT WRITTEN
CONSENT OF TRACHTENBERG ARCHITECTS.

JOB: 1928

SHEET:

PERSPECTIVE
VIEWS

A3.7

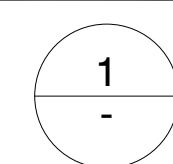

VIEW ALONG SAN PABLO - LOOKING NORTH



**1201
SAN PABLO
MIXED-USE**

Berkeley, CA 94706

- 03.11.2021 SB-330 PRE-APPLICATION
- 04.29.2021 ZONING APPLICATION
- 07.13.2021 ZONING COMPLETENESS
- 08.30.2021 ZONING COMPLETENESS

ALL DRAWINGS AND WRITTEN MATERIAL APPEARING
HEREIN CONSTITUTE ORIGINAL AND UNPUBLISHED
WORK OF THE ARCHITECT AND MAY NOT BE
DUPLICATED, USED OR DISCLOSED WITHOUT WRITTEN
CONSENT OF TRACHTENBERG ARCHITECTS.

JOB: 1928

SHEET:

PERSPECTIVE
VIEWS

A3.8

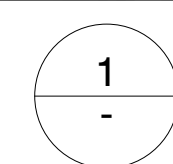

VIEW ALONG HARRISON - LOOKING EAST

2421 Fourth Street
Berkeley, California 94710
510.649.1414
www.TrachtenbergArch.com



**1201
SAN PABLO
MIXED-USE**

Berkeley, CA 94706

- 03.11.2021 SB-330 PRE-APPLICATION
- 04.29.2021 ZONING APPLICATION
- 07.13.2021 ZONING COMPLETENESS
- 08.30.2021 ZONING COMPLETENESS

ALL DRAWINGS AND WRITTEN MATERIAL APPEARING
HEREIN CONSTITUTE ORIGINAL AND UNPUBLISHED
WORK OF THE ARCHITECT AND MAY NOT BE
DUPLICATED, USED OR DISCLOSED WITHOUT WRITTEN
CONSENT OF TRACHTENBERG ARCHITECTS.

JOB: 1928

SHEET:

PERSPECTIVE
VIEWS

A3.9

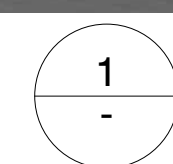

VIEW ALONG HARRISON - LOOKING WEST



4 HARRISON LOOKING EAST - AFTER



2 SAN PABLO LOOKING SOUTH - AFTER



3 HARRISON LOOKING EAST - BEFORE



1 SAN PABLO LOOKING SOUTH - BEFORE



**1201
SAN PABLO
MIXED-USE**

Berkeley, CA 94706

- 03.11.2021 SB-330 PRE-APPLICATION
- 04.29.2021 ZONING APPLICATION
- 07.13.2021 ZONING COMPLETENESS
- 08.30.2021 ZONING COMPLETENESS

ALL DRAWINGS AND WRITTEN MATERIAL APPEARING HEREIN CONSTITUTE ORIGINAL AND UNPUBLISHED WORK OF THE ARCHITECT AND MAY NOT BE DUPLICATED, USED OR DISCLOSED WITHOUT WRITTEN CONSENT OF TRACHTENBERG ARCHITECTS.

JOB: 1928

SHEET:
PHOTO MATCH
PERSPECTIVES

2421 Fourth Street
Berkeley, California 94710
510.649.1414
www.TrachtenbergArch.com



**1201
SAN PABLO
MIXED-USE**

Berkeley, CA 94706

- 03.11.2021 SB-330 PRE-APPLICATION
- 04.29.2021 ZONING APPLICATION
- 07.13.2021 ZONING COMPLETENESS
- 08.30.2021 ZONING COMPLETENESS

ALL DRAWINGS AND WRITTEN MATERIAL APPEARING HEREIN CONSTITUTE ORIGINAL AND UNPUBLISHED WORK OF THE ARCHITECT AND MAY NOT BE DUPLICATED, USED OR DISCLOSED WITHOUT WRITTEN CONSENT OF TRACHTENBERG ARCHITECTS.

JOB: 1928

SHEET:

BUILDING SECTION

A4.1

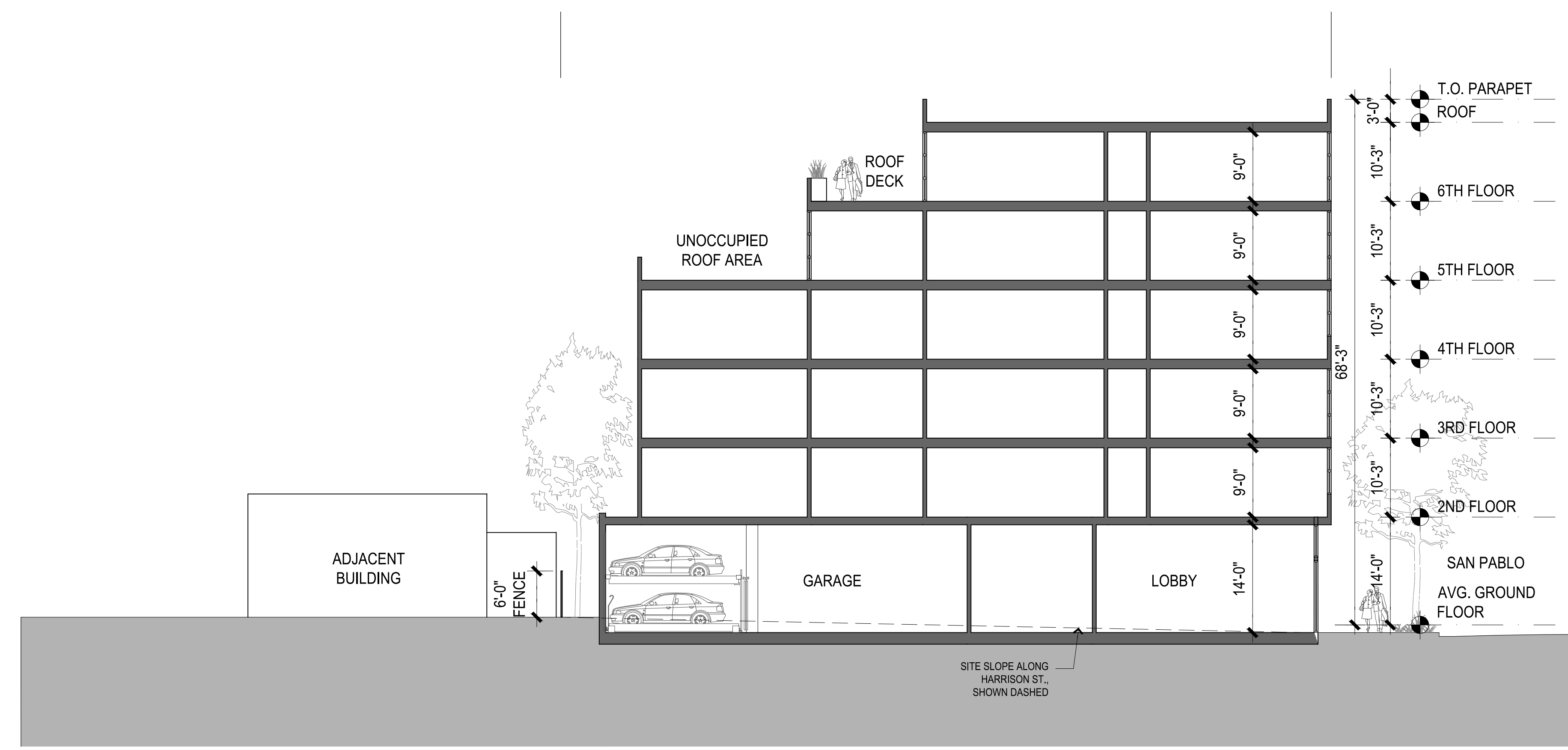

2 E-W SECTION THROUGH PODIUM GARDEN
3/64"=1'-0" @ 11X17 3/32"=1'-0" @ 24X36

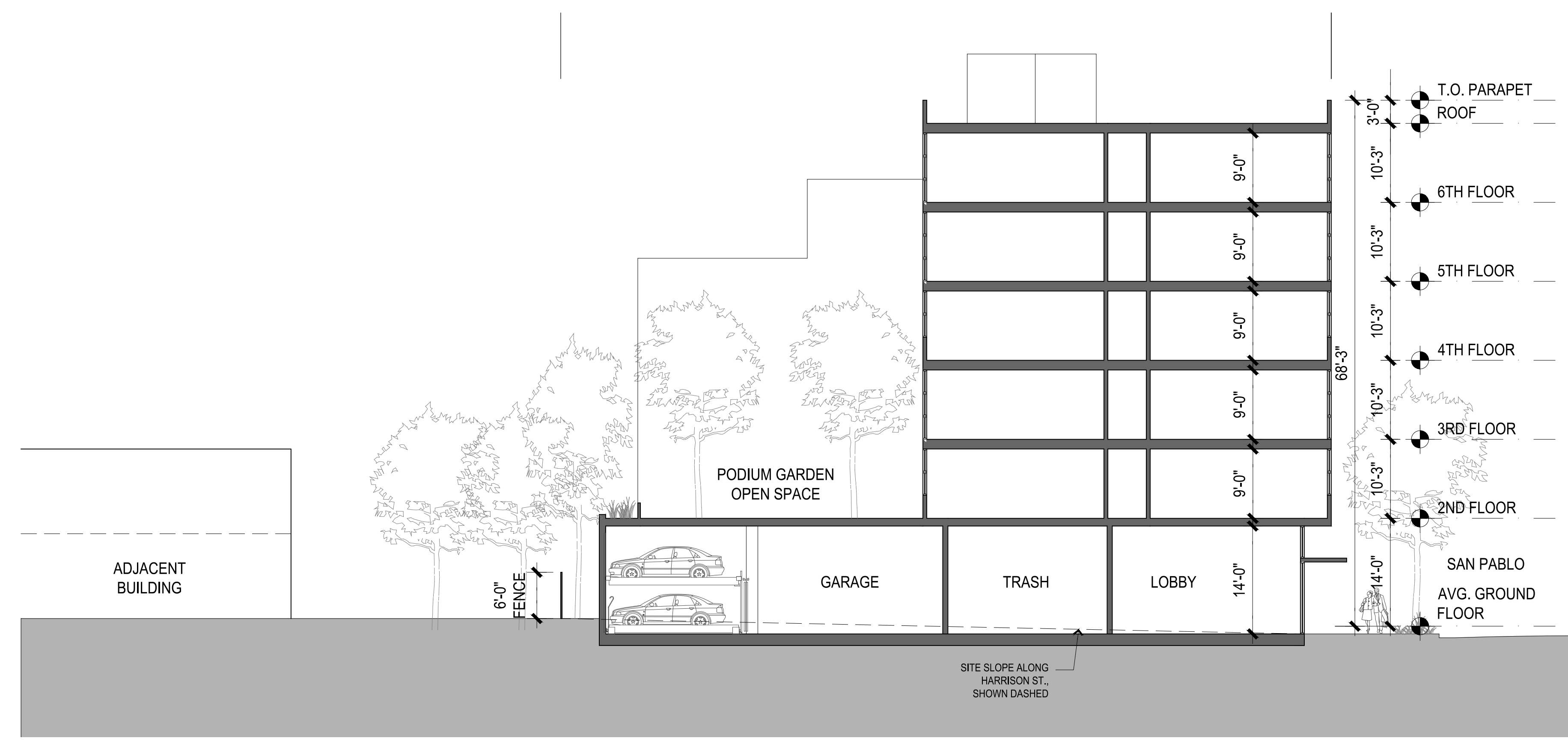
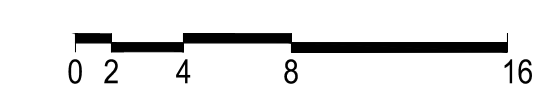

1 E-W SECTION
3/64"=1'-0" @ 11X17 3/32"=1'-0" @ 24X36

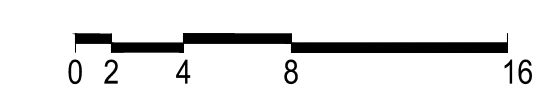

2421 Fourth Street
Berkeley, California 94710
510.649.1414
www.TrachtenbergArch.com



1201
SAN PABLO
MIXED-USE

Berkeley, CA 94706

- 03.11.2021 SB-330 PRE-APPLICATION
- 04.29.2021 ZONING APPLICATION
- 07.13.2021 ZONING COMPLETENESS
- 08.30.2021 ZONING COMPLETENESS

ALL DRAWINGS AND WRITTEN MATERIAL APPEARING HEREIN CONSTITUTE ORIGINAL AND UNPUBLISHED WORK OF THE ARCHITECT AND MAY NOT BE DUPLICATED, USED OR DISCLOSED WITHOUT WRITTEN CONSENT OF TRACHTENBERG ARCHITECTS.

JOB: 1928

SHEET:

WALL SECTIONS & DETAILS

A4.2

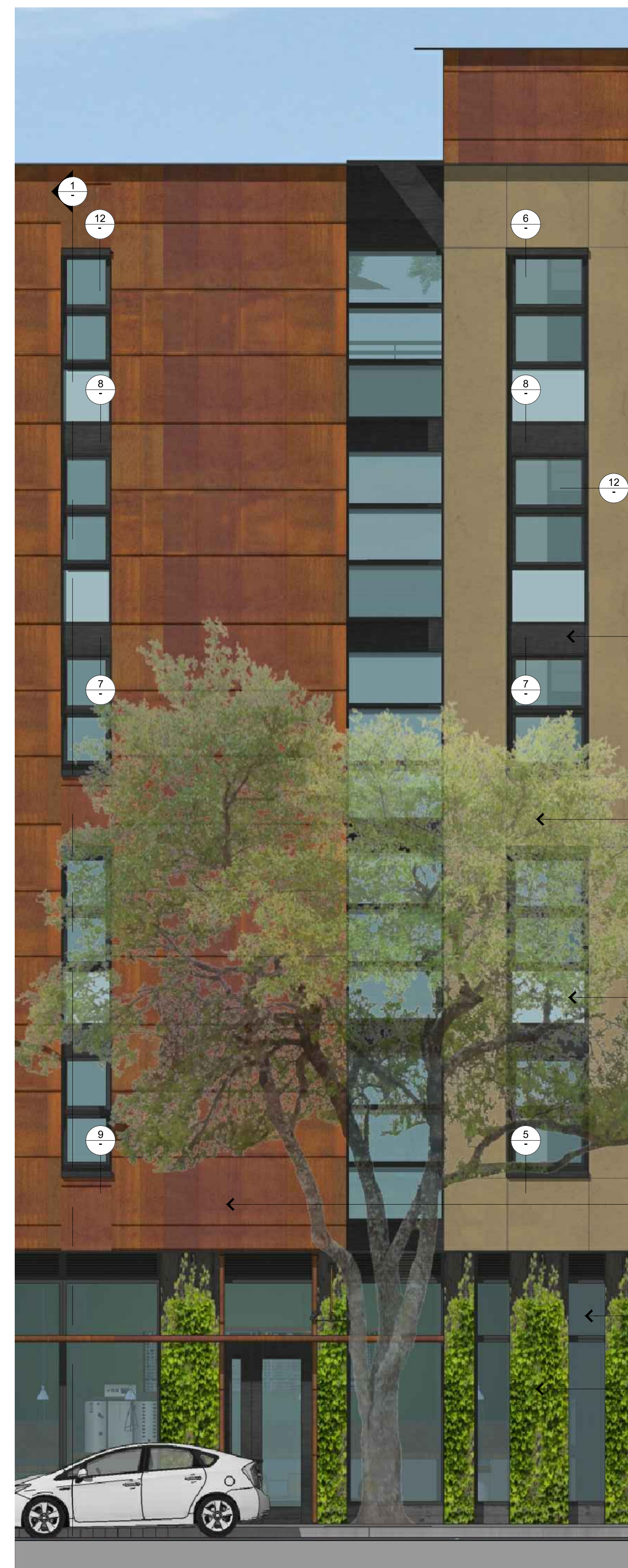

2 ELEVATION DETAIL
1/8"=1'-0" @ 11X17 1/4"=1'-0" @ 24X36

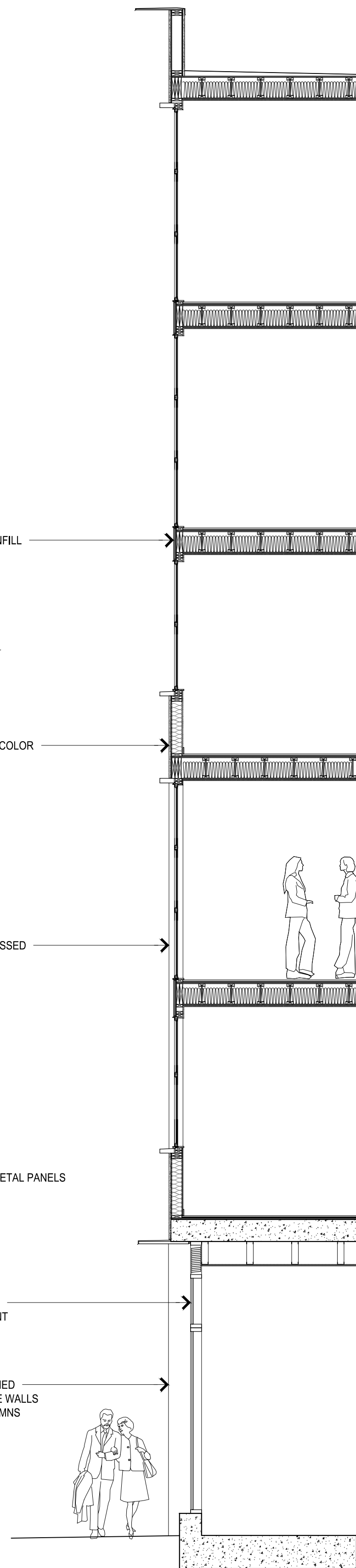

1 SECTION
1/8"=1'-0" @ 11X17 1/4"=1'-0" @ 24X36

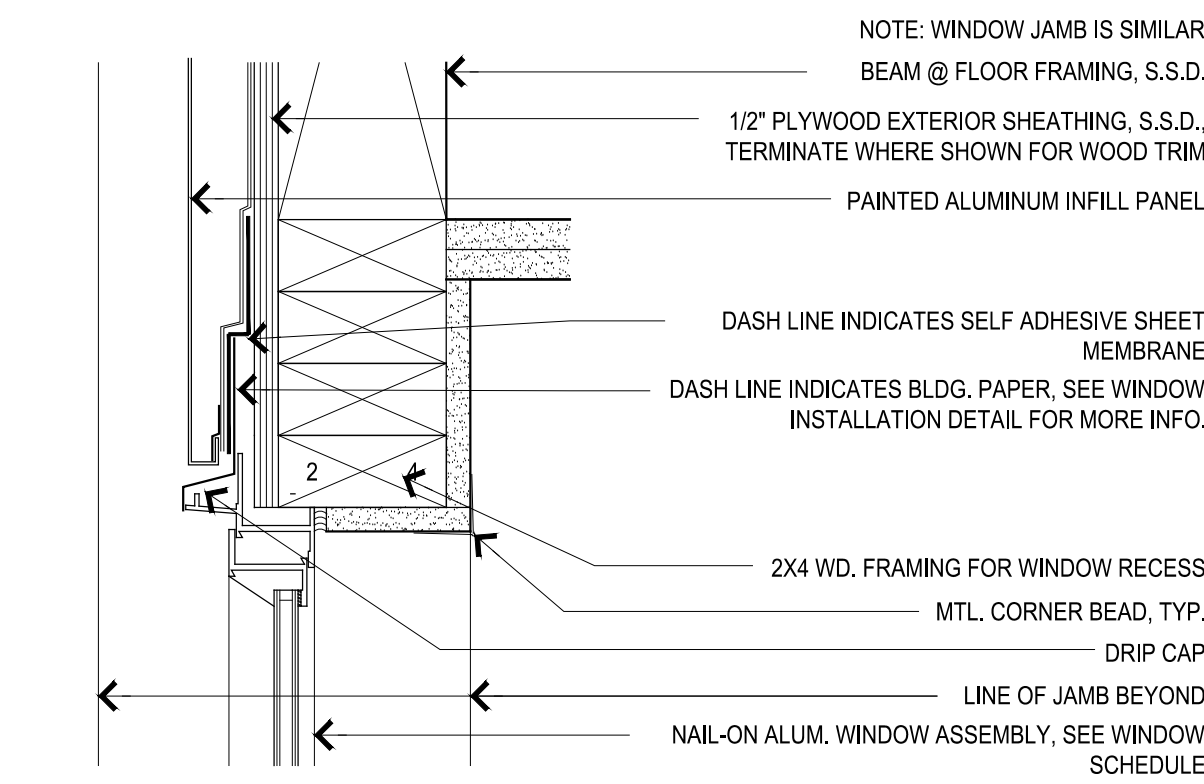

8 HEAD @ FILL PANEL
3"=1'-0"

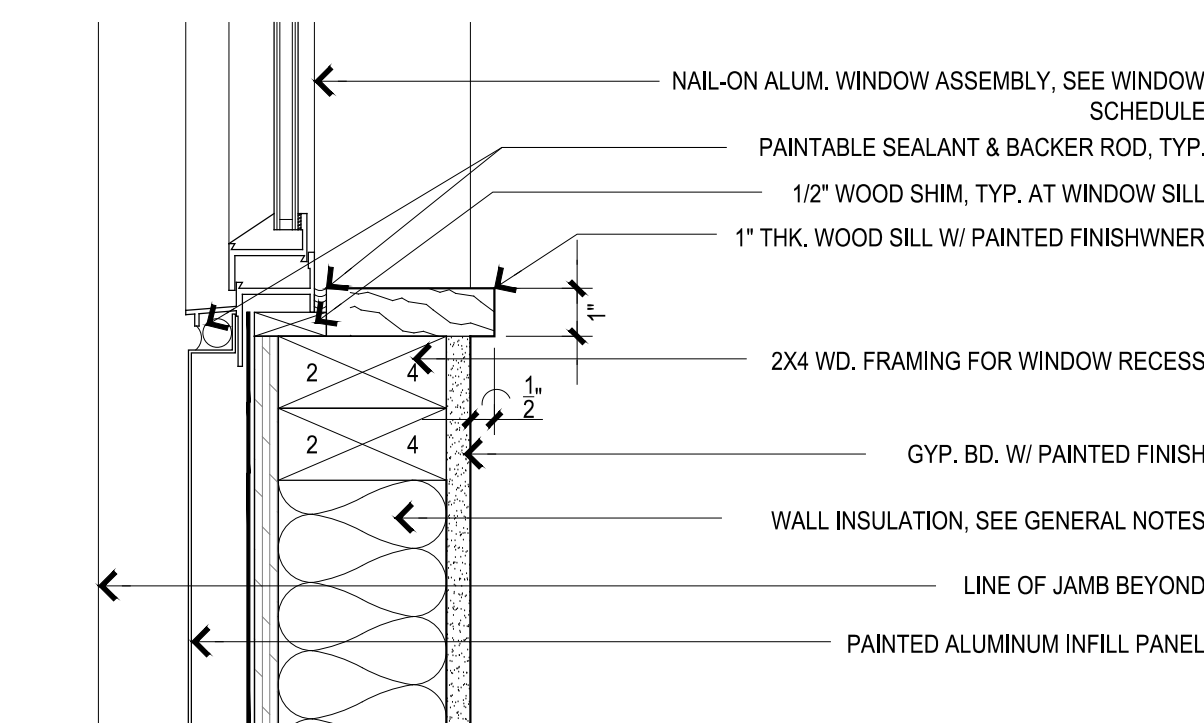

7 SILL AT FILL PANEL
3"=1'-0"

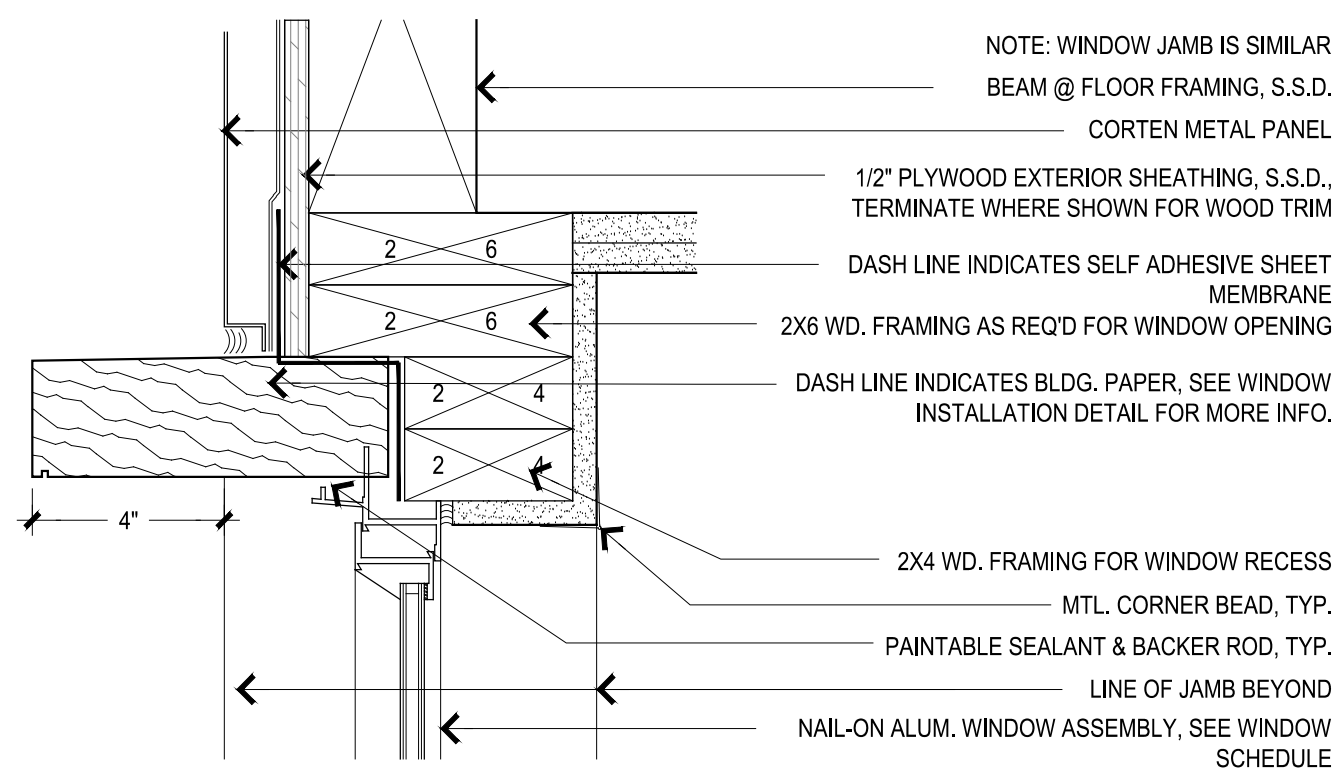

10 TYP. HEAD @ CORTEN
3"=1'-0"

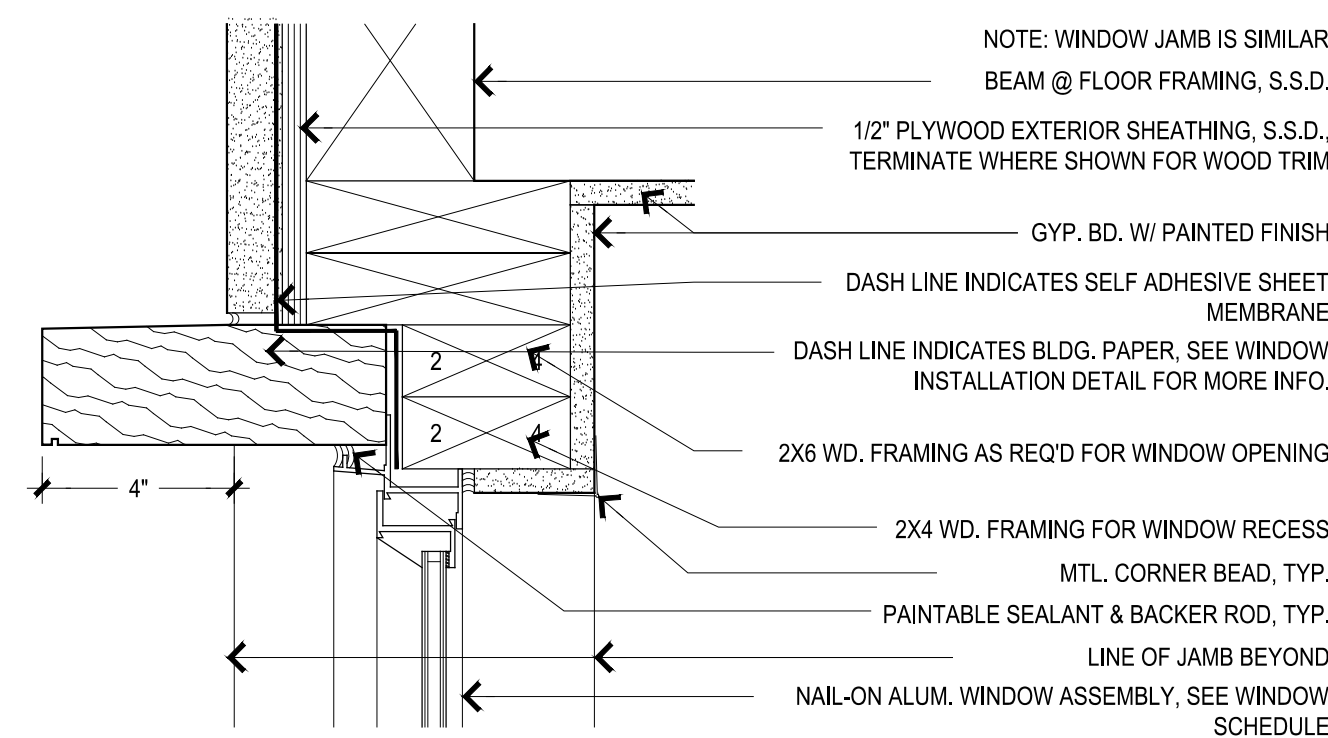

6 TYP. STUCCO HEAD / JAMB
3"=1'-0"

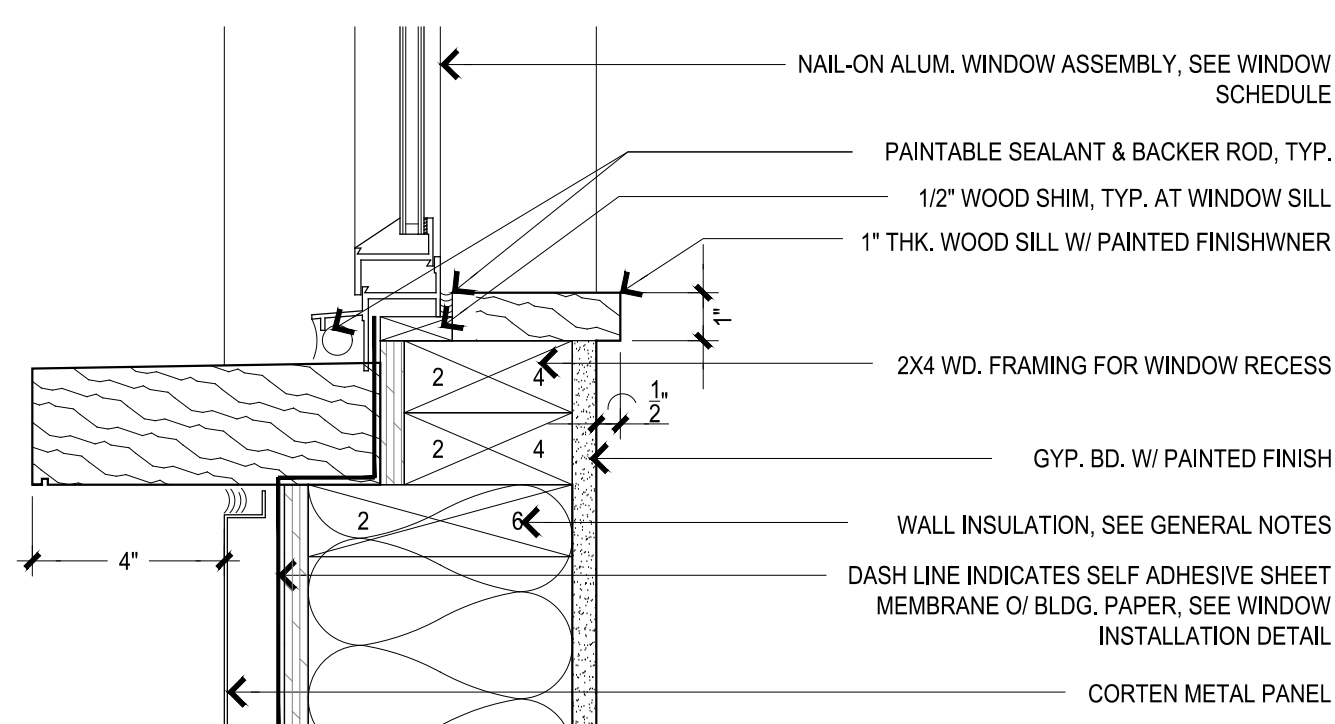

9 TYP. SILL @ CORTEN
3"=1'-0"

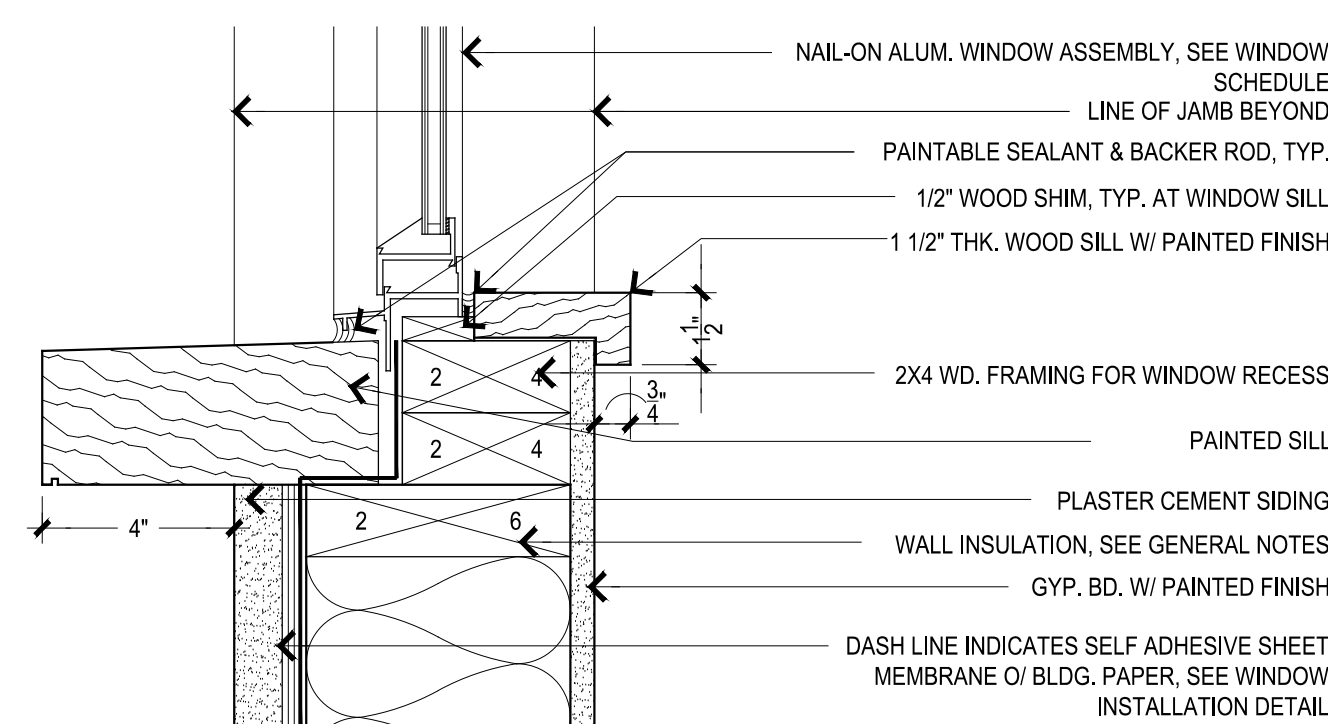

5 TYP. STUCCO SILL
3"=1'-0"



**1201
SAN PABLO
MIXED-USE**

Berkeley, CA 94706

- 03.11.2021 SB-330 PRE-APPLICATION
- 04.29.2021 ZONING APPLICATION
- 07.13.2021 ZONING COMPLETENESS
- 08.30.2021 ZONING COMPLETENESS

ALL DRAWINGS AND WRITTEN MATERIAL APPEARING
HEREIN CONSTITUTE ORIGINAL AND UNPUBLISHED
WORK OF THE ARCHITECT AND MAY NOT BE
DUPLICATED, USED OR DISCLOSED WITHOUT WRITTEN
CONSENT OF TRACHTENBERG ARCHITECTS.

JOB: 1928

SHEET:

MATERIAL
BOARD

MAT



INTEGRAL COLOR STUCCO
W/ SMOOTH TROWEL FINISH



METAL INFILL PANEL

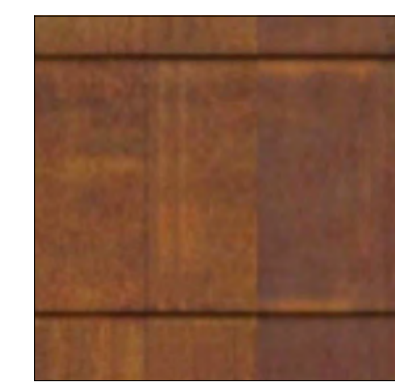

CORTEN METAL
PANEL



CORTEN METAL PANELS

INTEGRAL COLOR
STUCCO W/ SMOOTH
TROWEL FINISH

ALUMINUM
STOREFRONT

METAL INFILL
PANEL

CAST-IN-PLACE
CONCRETE

STEEL EAVE, PTD.

1 WEST ELEVATION

3/32" = 1'-0" @ 11X17 3/16" = 1'-0" @ 24X36

0 4 8 16

2421 Fourth Street
Berkeley, California 94710
510.649.1414
www.TrachtenbergArch.com



**1201
SAN PABLO
MIXED-USE**

Berkeley, CA 94706

- 03.11.2021 SB-330 PRE-APPLICATION
- 04.29.2021 ZONING APPLICATION
- 07.13.2021 ZONING COMPLETENESS
- 08.30.2021 ZONING COMPLETENESS

ALL DRAWINGS AND WRITTEN MATERIAL APPEARING
HEREIN CONSTITUTE ORIGINAL AND UNPUBLISHED
WORK OF THE ARCHITECT AND MAY NOT BE
DUPLICATED, USED OR DISCLOSED WITHOUT WRITTEN
CONSENT OF TRACHTENBERG ARCHITECTS.

JOB: 1928

SHEET:

CONCEPTUAL
GRADING PLAN

G-01

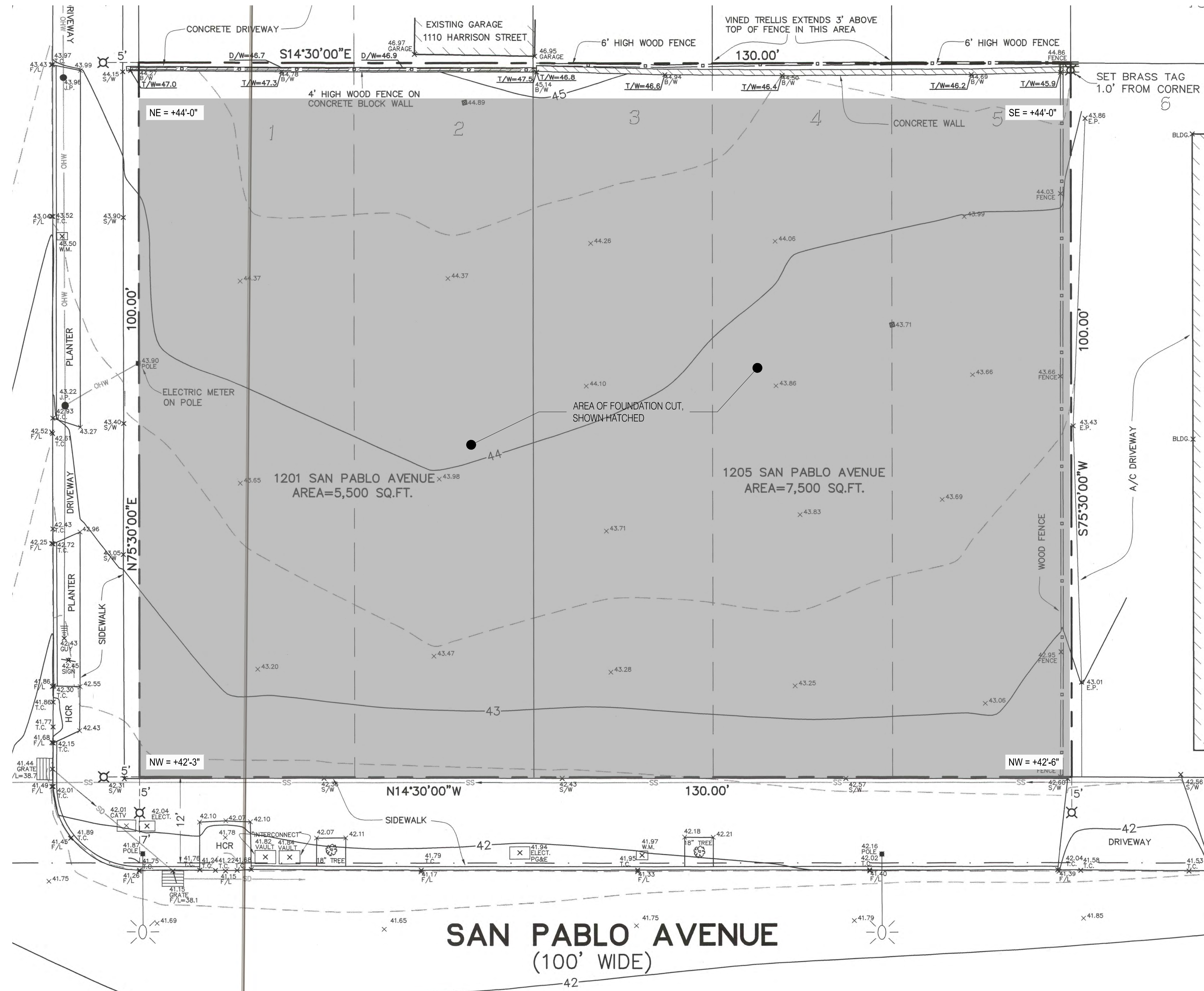

ESTIMATED QUANTITIES AND LOCATIONS OF FOUNDATION CUTS

	FEET	YARDS		
TOTAL CUBIC YARDS OF CUT		1115 (CUBIC YARDS)		
TOTAL AREA OF CUT	12346	1372 (SQUARE YARDS)		
AVERAGE DEPTH OF CUT	EXISTING ELEVATION (FT)	FINAL ELEVATION (FT)	2.4375	0.81 (YARDS)
CORNER 1 - NW	42.25	40.75	1.5	0.5 (YARDS)
CORNER 2 - NE	44	40.75	3.25	1.083333 (YARDS)
CORNER 3 - SE	44	40.75	3.25	1.08 (YARDS)
CORNER 4 - SW	42.5	40.75	1.75	0.583333 (YARDS)

2 ESTIMATED CUT/FILL DATA

1 CONCEPTUAL GRADING PLAN

1/16" = 1'-0" @ 11X17 1/8" = 1'-0" @ 24X36

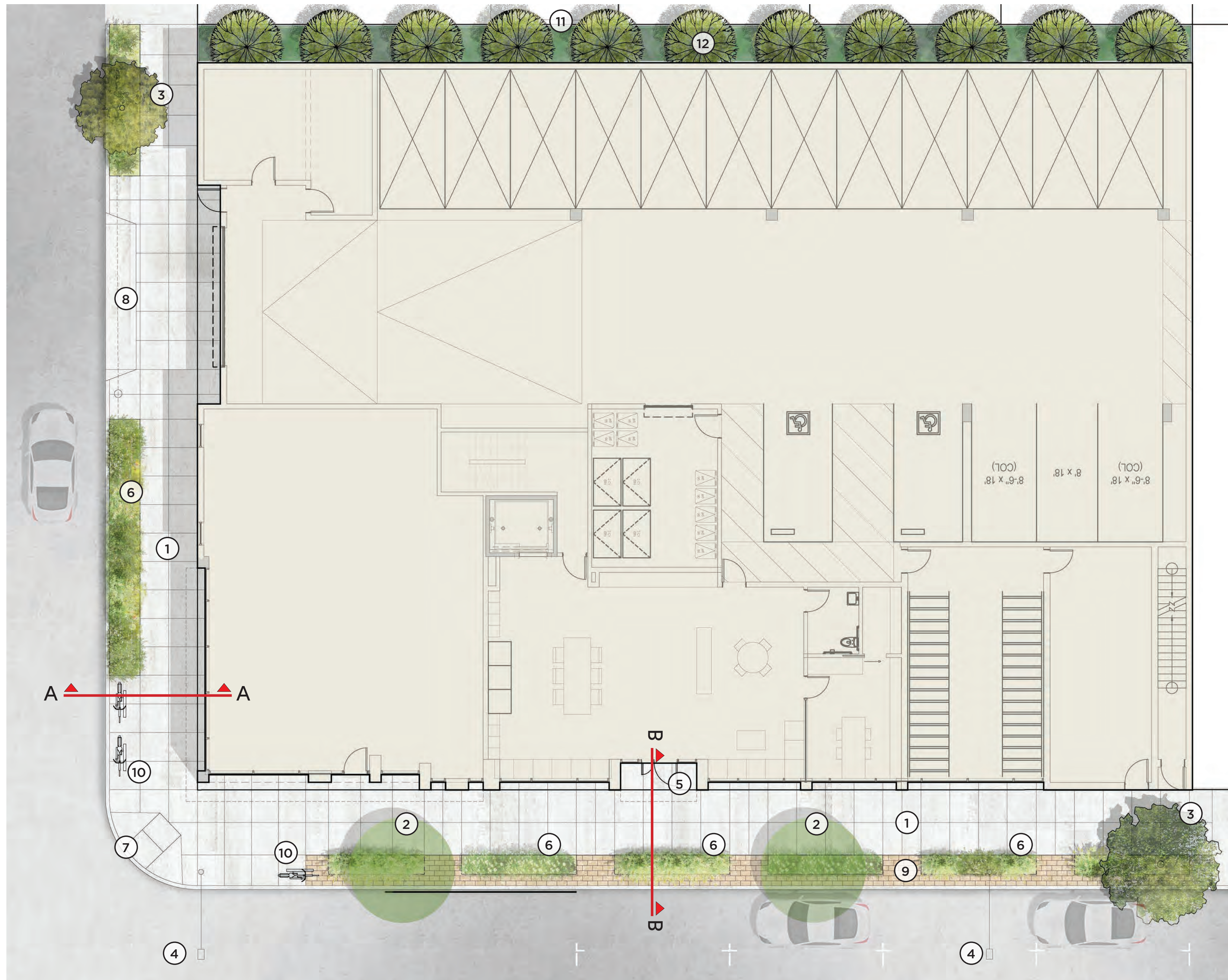

LEGEND

1. CONCRETE SIDEWALK PAVING
2. EXISTING STREET TREE, SEE SPECIFICATION
3. NEW STREET TREE
4. EXISTING STREET LIGHT
5. ENTRY TO LOBBY
6. AT-GRADE PLANTING
7. CURB RAMP
8. DRIVEWAY TO GARAGE
9. ENHANCED PAVING
10. NEW BIKE RACKS TYP. OF (3)
11. WOOD FENCE
12. LANDSCAPE MAINTENANCE AREA

TRACHTENBERG ARCHITECTS

2421 Fourth Street
Berkeley, California 94710
510.649.1414
www.TrachtenbergArch.com

MILLER COMPANY
landscape architects

1585 FOLSOM ST. SAN FRANCISCO, CA 94103
415.252.7288 www.millercomp.com

1201 SAN PABLO MIXED-USE

Berkeley, CA 94706

07.13.2021 ZONING COMPLETENESS
08.30.2021 ZONING COMPLETENESS

PLANTING NOTES

1. PLANT SPECIES SELECTED FOR DROUGHT TOLERANCE, ECOLOGICAL BENEFIT AND SITE SUITABILITY IN TERMS OF SIZE, SHADE/SUN-TOLERANCE, AND MAINTENANCE NEEDS. PLANT MATERIAL FROM VARIOUS CALIFORNIA HABITATS HAS BEEN EMPHASIZED.
2. BAY-FRIENDLY BEST PRACTICES REGARDING MULCHING AND SOIL HEALTH WILL BE IMPLEMENTED TO FACILITATE PLANT GROWTH, INCLUDING SPECIFICATION OF ORGANIC SOIL AMENDMENTS AND COMPOST.
3. THE PLANTING DESIGN WILL GROUP PLANTS WITH SIMILAR EVAPOTRANSPIRATION FACTORS WITHIN LEGIBLE ZONES. EVAPOTRANSPIRATION WILL BE ASSIGNED PER WUCOLS VERSION IV.
4. THE LANDSCAPE ARCHITECT WILL PROVIDE PLANT AND SOIL MAINTENANCE RECOMMENDATIONS AS PART OF THE PROJECT SPECIFICATIONS.
5. LAWN AND TURF AREAS WILL NOT BE INCLUDED IN THE PROJECT.

IRRIGATION NOTES

1. THE IRRIGATION SYSTEM WILL BE DESIGNED BY A LICENSED IRRIGATION PROFESSIONAL.
2. A DEDICATED EBMUD METER OR SUBMETER WILL BE PROVIDED FOR THE IRRIGATION SYSTEM DESIGN WITH LOCATION AND POINT OF CONNECTION NOTED.
3. A MANUAL SHUTOFF VALVE, REDUCED PRESSURE BACKFLOW PREVENTER AND FLOW SENSOR WITH MASTER SHUT OFF VALVE WILL BE PROVIDED AFTER THE POINT OF CONNECTION.
4. WATER PRESSURE AND FLOW RATES AT POINT OF CONNECTION AND ALL REMOTE CONTROL VALVES WILL BE INDICATED ON IRRIGATION PLANS.
5. IRRIGATION PLANS WILL SHOW SCHEMATIC LOCATION FOR ALL MAINLINES, LATERALS, SLEEVES AND REMOTE CONTROL VALVES.
6. REMOTE CONTROL VALVES WILL BE OPERATED BY A SMART, WEATHER-BASED IRRIGATION CONTROLLER WITH RAIN SENSOR MOUNTED IN AN APPROPRIATE LOCATION.
7. ALL PLANTED AREAS WILL BE WATERED USING HIGH-EFFICIENCY IRRIGATION TECHNOLOGY, SUCH AS DRIP LINES AND BUBBLERS WITH FLUSH AND AIR RELIEF VALVES WHERE REQUIRED. ALL COMPONENTS SHALL HAVE FIXED FLOW RATES.
8. IRRIGATION ZONES WILL BE GROUPED BY WATER DEMAND AND THE OVERALL PLANTING PLAN WILL COMPLY WITH WATER USE LIMITATIONS OUTLINED IN THE LATEST WATER EFFICIENT LANDSCAPE ORDINANCE.



BIKE RACK

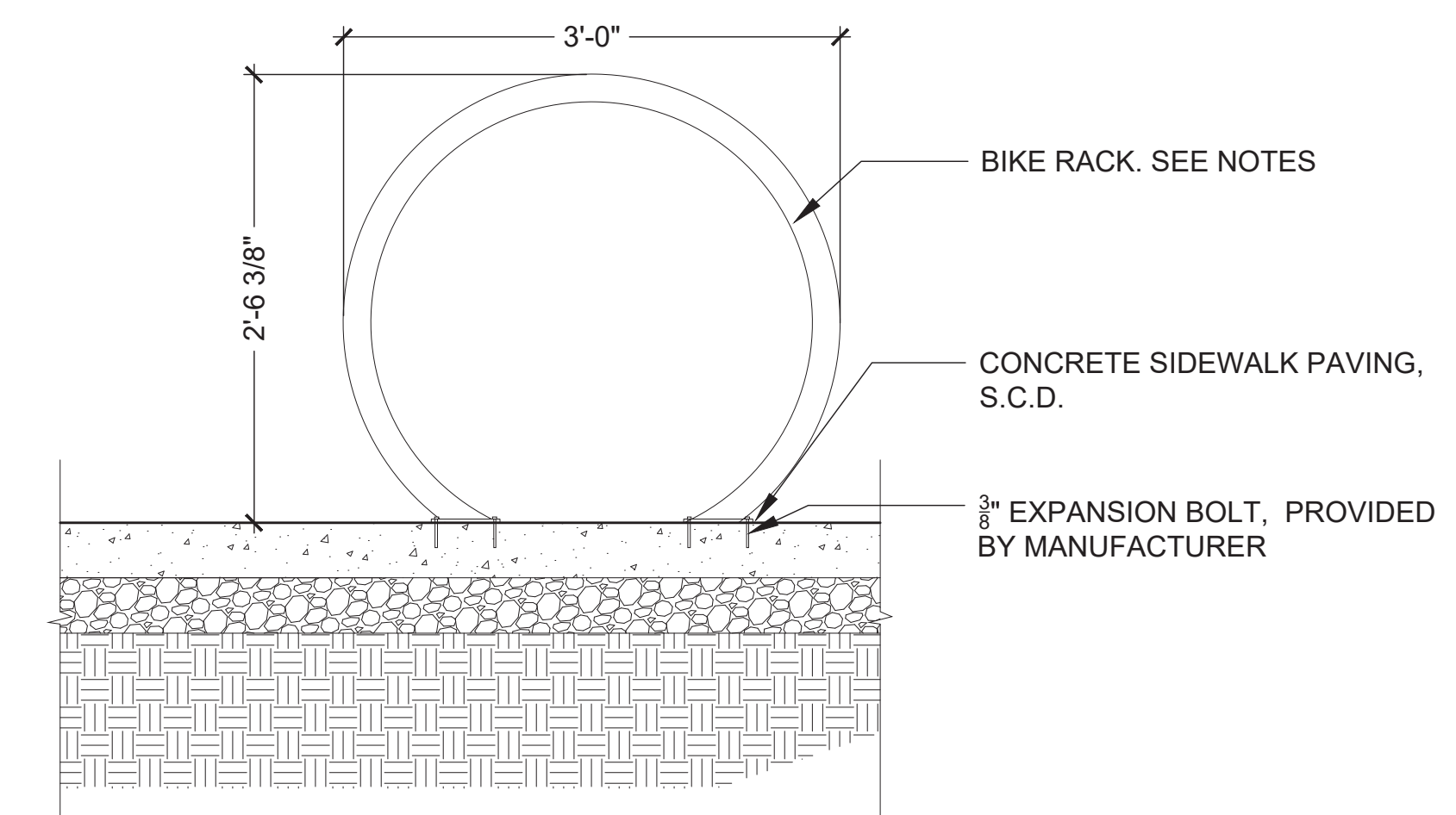

BIKE RACK: 'WELLE' CIRCULAR, SQUARE TUBE, HOT-DIPPED GALVANIZED FINISH, SURFACE MOUNT, MODEL: WCR02-SQ-SF-G.

BIKE RACK DETAIL

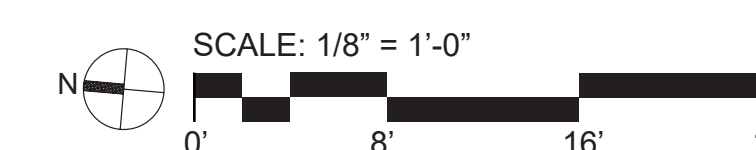

ALL DRAWINGS AND WRITTEN MATERIAL APPEARING HEREIN CONSTITUTE ORIGINAL AND UNPUBLISHED WORK OF THE ARCHITECT AND MAY NOT BE DUPLICATED, USED OR DISCLOSED WITHOUT WRITTEN CONSENT OF TRACHTENBERG ARCHITECTS.

JOB: 1928

SHEET:

LANDSCAPE PLANS GROUND LEVEL

L1.1

2421 Fourth Street
Berkeley, California 94710
510.649.1414
www.TrachtenbergArch.com

MILLER COMPANY
landscape architects

1585 FOLSOM ST. SAN FRANCISCO, CA 94103
415.252.7288 www.millercomp.com

**1201
SAN PABLO
MIXED-USE**

Berkeley, CA 94706

07.13.2021 ZONING COMPLETENESS

08.30.2021 ZONING COMPLETENESS

ALL DRAWINGS AND WRITTEN MATERIAL APPEARING
HEREIN CONSTITUTE ORIGINAL AND UNPUBLISHED
WORK OF THE ARCHITECT AND MAY NOT BE
DUPLICATED, USED OR DISCLOSED WITHOUT WRITTEN
CONSENT OF TRACHTENBERG ARCHITECTS.

JOB: 1928

SHEET:

**LANDSCAPE PLAN
LEVEL 2**

L1.2

LEGEND

1. UNIT PAVERS
2. RAISED METAL PLANTERS
3. SPECIMEN TREES
4. INTENSIVE VEGETATED ROOF
5. MOVABLE CHAIRS WITH SIDE TABLES
6. DINING TABLES AND CHAIRS
7. LOUNGE CHAIRS AND TABLES
8. OUTDOOR KITCHEN COUNTER
9. OVERHEAD SHADE STRUCTURE
10. METAL PAVING EDGE
11. SCREEN
12. 42" PERFORATED METAL SCREEN
13. GRAVEL

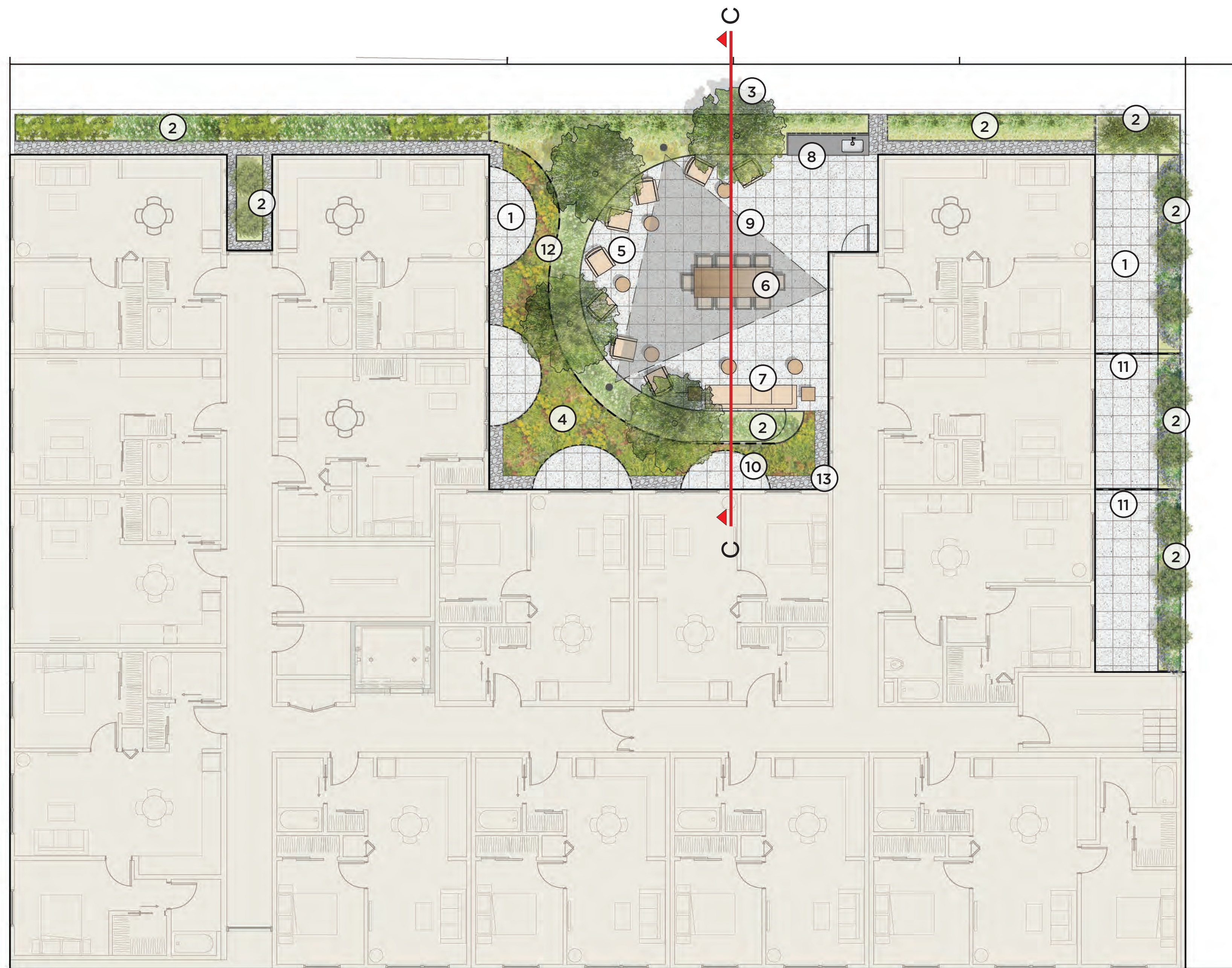

2ND LEVEL PLAN

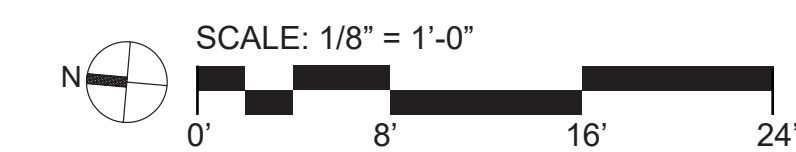

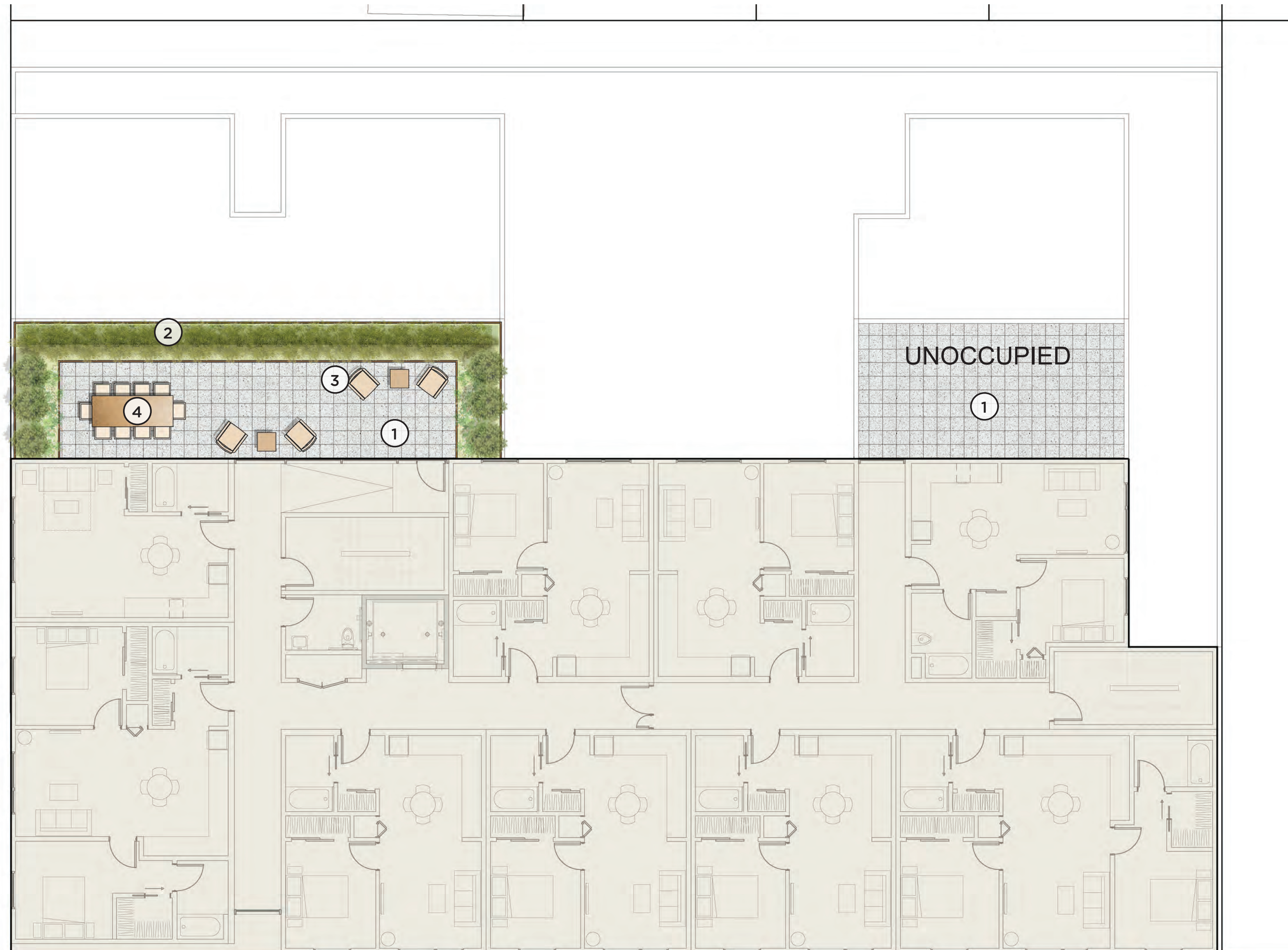

6TH LEVEL PLAN

LEGEND

- 1. UNIT PAVERS ON PEDESTALS
- 2. RAISED METAL PLANTERS
- 3. MOVABLE CHAIRS WITH SIDE TABLES
- 4. DINING TABLES AND CHAIRS

2421 Fourth Street
 Berkeley, California 94710
 510.649.1414
 www.TrachtenbergArch.com

MILLER COMPANY
 landscape architects

1585 FOLSOM ST. SAN FRANCISCO, CA 94103
 415.252.7288 www.millercomp.com

**1201
 SAN PABLO
 MIXED-USE**

Berkeley, CA 94706

07.13.2021 ZONING COMPLETENESS
 08.30.2021 ZONING COMPLETENESS

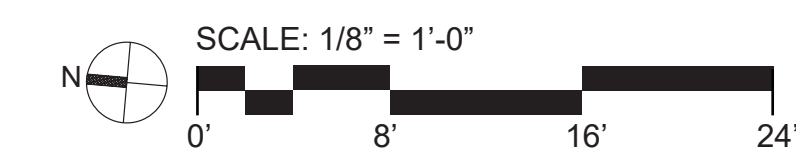

ALL DRAWINGS AND WRITTEN MATERIAL APPEARING
 HEREIN CONSTITUTE ORIGINAL AND UNPUBLISHED
 WORK OF THE ARCHITECT AND MAY NOT BE
 DUPLICATED, USED OR DISCLOSED WITHOUT WRITTEN
 CONSENT OF TRACHTENBERG ARCHITECTS.

JOB: 1928

SHEET:

**LANDSCAPE PLAN
 LEVEL 6**

L1.3

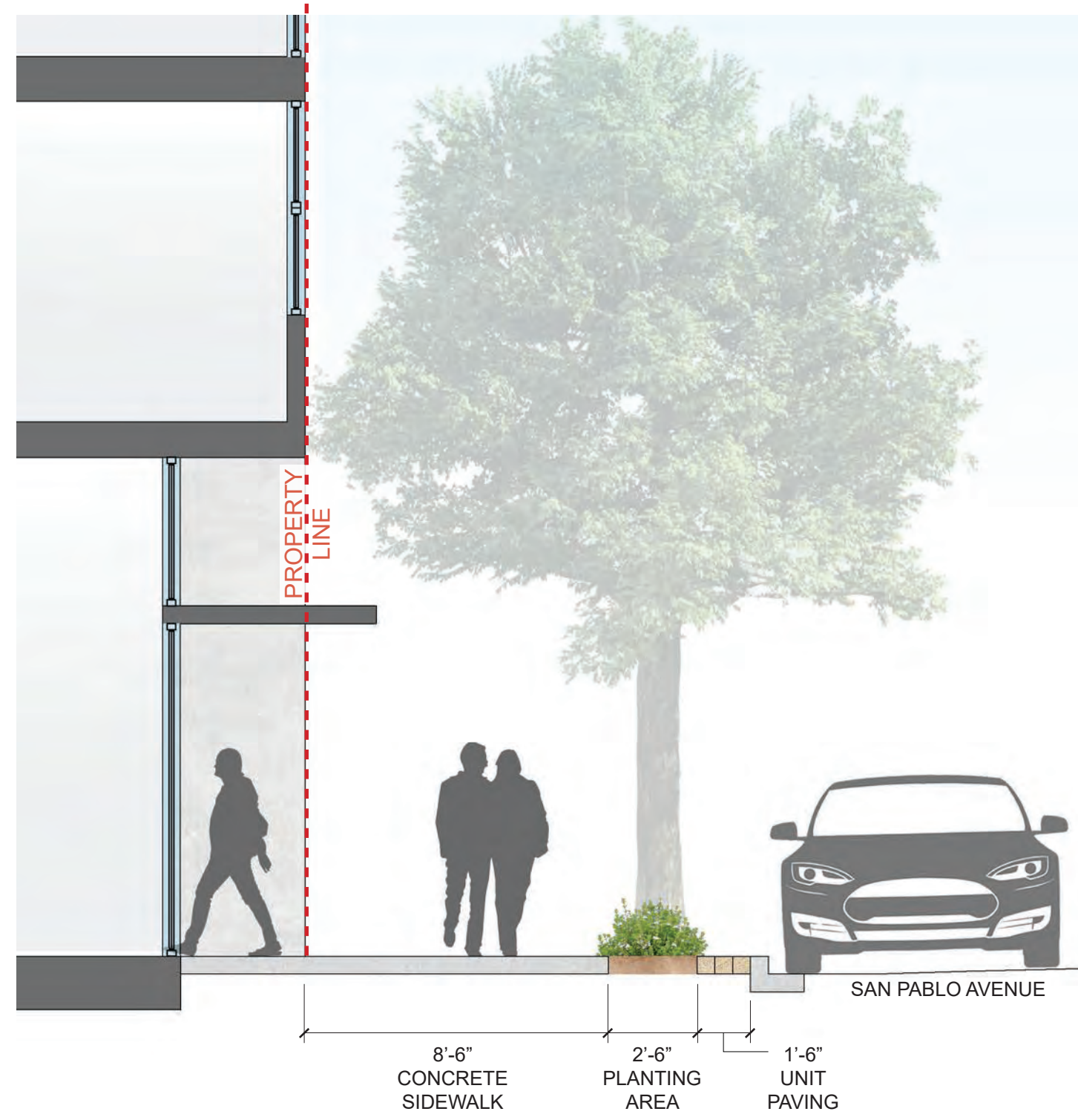

SECTION A-A: SAN PABLO AVE

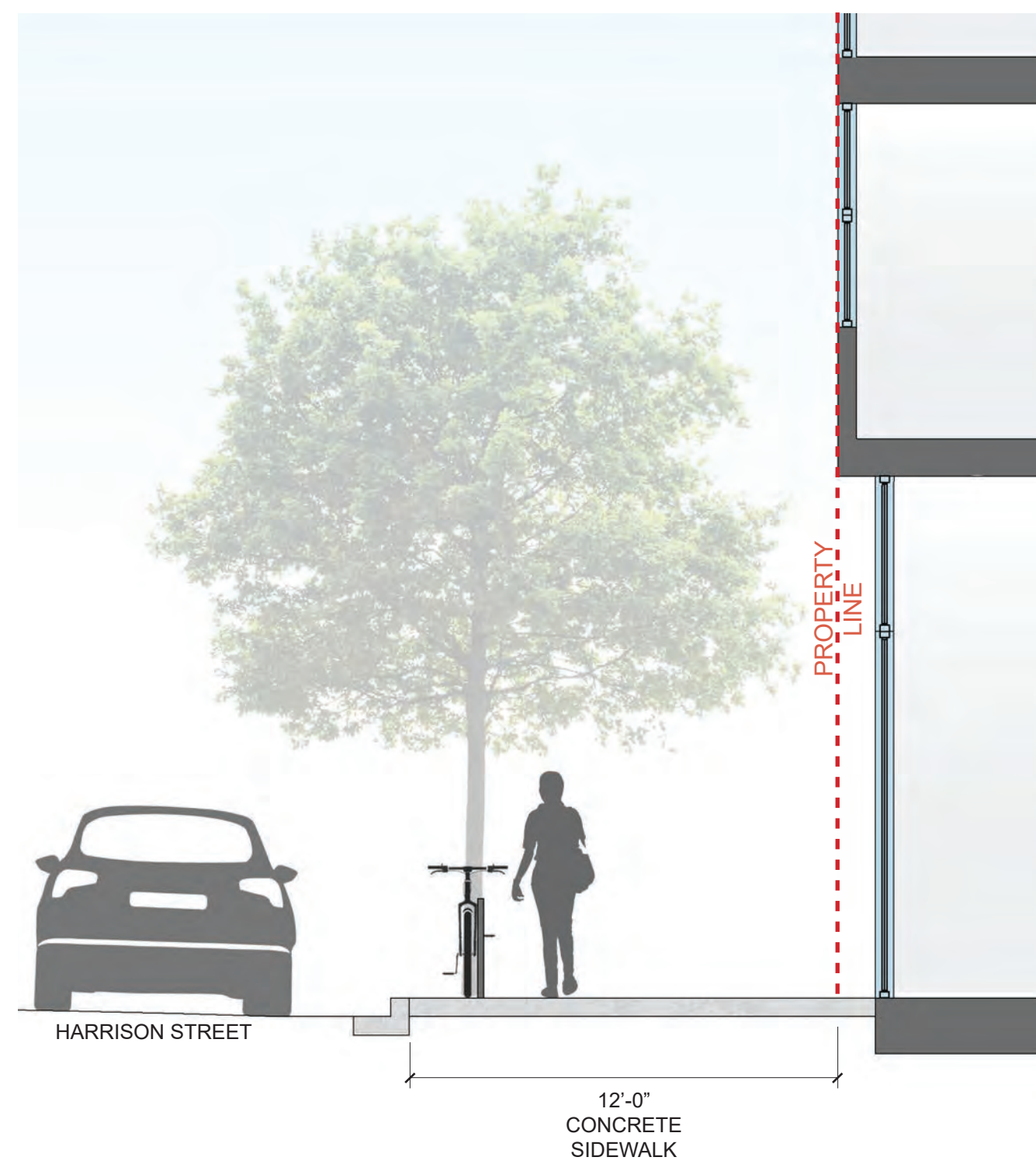

SECTION B-B: HARRISON ST

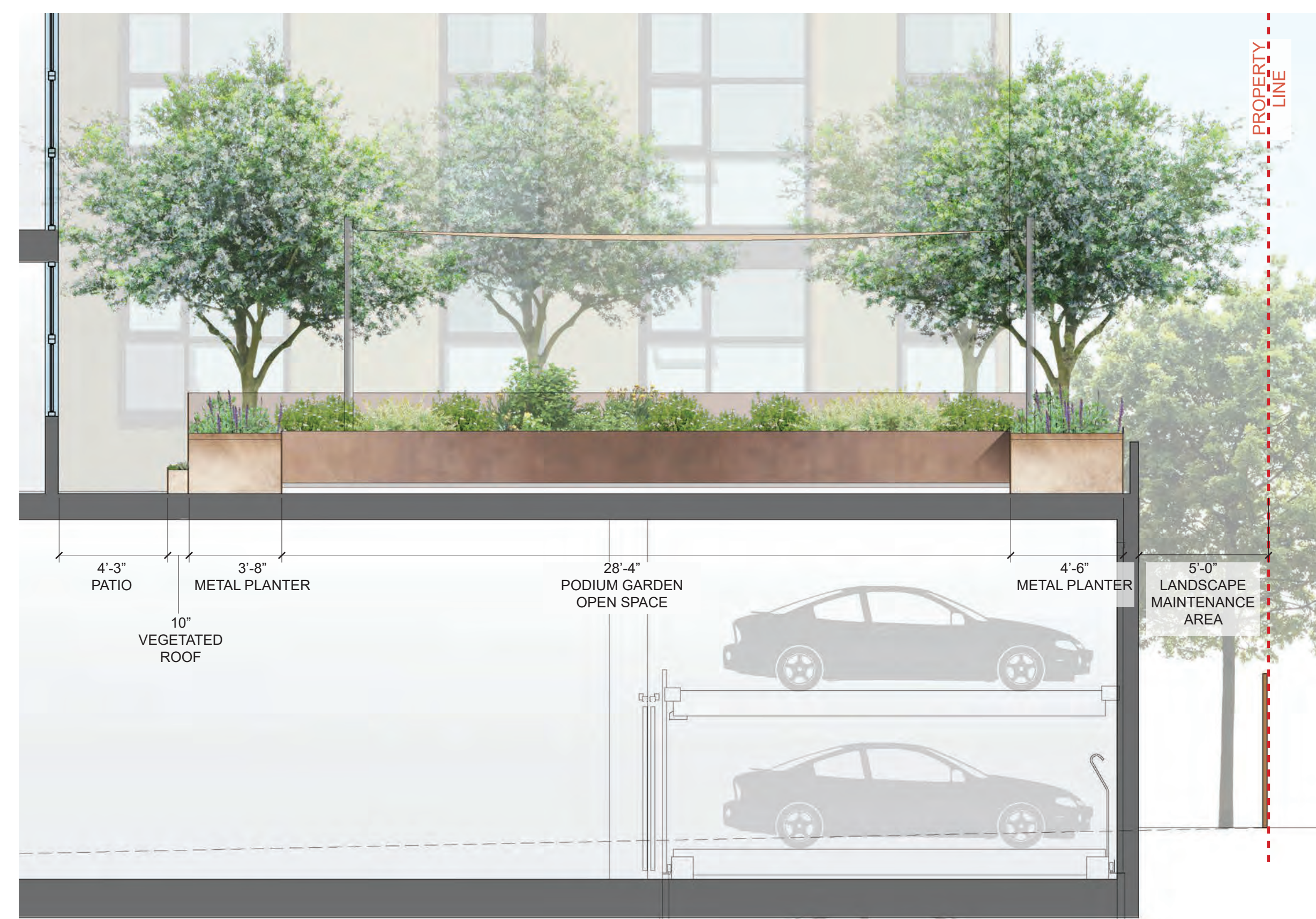

SECTION C-C: PODIUM GARDEN

1201
SAN PABLO
MIXED-USE

Berkeley, CA 94706

07.13.2021 ZONING COMPLETENESS

08.30.2021 ZONING COMPLETENESS

OPEN SPACE TABLE				
	UNITS	RATIO	TOTAL	LANDSCAPE AREA
TOTAL UNITS	66	40	2,640	
TOTAL AREA PROVIDED			2,514	1,346
PODIUM LEVEL GARDEN			1,640	902
PODIUM LEVEL PATIOS			120	115
LEVEL 6 ROOF DECK			754	329

TOTAL LANDSCAPED AREA ON EACH LEVEL

STREET TREES



David Elm
Ulmus davidiana var.
japonica



Bronze Loquat
Eriobotrya deflexa

GROUND LEVEL



Box Leaf Azara
Azara microphylla



Creeping Fig
Ficus pumila



Stalked Bulbine
Bulbine frutescens



California Fuchsia
Epilobium canum



California Fescue
Festuca californica



Douglas Iris
Iris douglasiana

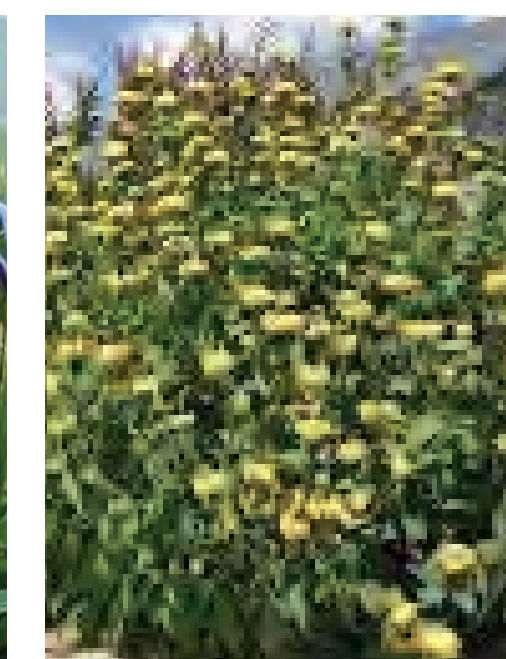

Jerusalem Sage
Phlomis fruticosa

2nd LEVEL



Evergreen Dogwood
Cornus capitata



Dwarf Mahonia
Mahonia aquifolium repens



Coffeeberry
Frangula californica 'Seaview'



Giant Wildrye
Elymus condensatus



Island Alum Root
Heuchera maxima



Western Swordfern
Polystichum munitum



Hummingbird Sage
Salvia spathacea

6th LEVEL TERRACE



Mimulus aurantiacus 'Pt. Molate'



Santa Barbara Daisy
Erigeron karvinskianus

ALL DRAWINGS AND WRITTEN MATERIAL APPEARING HEREIN CONSTITUTE ORIGINAL AND UNPUBLISHED WORK OF THE ARCHITECT AND MAY NOT BE DUPLICATED, USED OR DISCLOSED WITHOUT WRITTEN CONSENT OF TRACHTENBERG ARCHITECTS.

JOB: 1928

SHEET:

LANDSCAPE
SECTIONS AND
PLANT PALETTE

L1.4