



Office of the City Manager

CONSENT CALENDAR

April 23, 2019

To: Honorable Mayor and Members of the City Council
From: Dee Williams-Ridley, City Manager
Submitted by: Scott Ferris, Director, Parks Recreation & Waterfront
Subject: Donation: Information Display Case at the Berkeley Rose Garden

RECOMMENDATION

Adopt a Resolution accepting a donation of an information display case valued at \$7,429 from the Friends of the Berkeley Rose Garden.

FISCAL IMPACTS OF RECOMMENDATION

The Friends of the Berkeley Rose Garden have raised funds in the amount of \$7,429 to obtain an information display case to be installed at the Berkeley Rose Garden. The case will be delivered to the City's Corporation Yard and will be installed by City staff at the Rose Garden.

CURRENT SITUATION AND ITS EFFECTS

The Friends of the Berkeley Rose Garden have raised funds to obtain a redwood information display case that was designed and constructed by Berkeley Mills Furniture and Cabinetry. The case will enable historic information and notices of activities to be posted in an attractive manner consistent with the aesthetics of the Berkeley Rose Garden. The Friends were able to make this offer thanks to donations from throughout the community from those who love the Garden, one of the City's civic treasures.

BACKGROUND

The City's Open Governance Ordinance (OGO) requires City Council disclosure and approval of any gift to the City in excess of \$1,000 (BMC Section 2.06.150, Ord. 7,166-N.S.)

ENVIRONMENTAL SUSTAINABILITY

The informational display case will be constructed by Berkeley Mills Furniture and Cabinetry, a local vendor. Berkeley Mills is committed to ecologically sound manufacturing and business practices. Because wood is the heart of their business, Berkeley Mills does everything possible to support sustainable forestry and the responsible use of this precious resource. This policy is consistent with the City's environmentally preferable purchasing policy, specifically section 3.7 Forest Conservation.

Donation: Information Display Case at the Berkeley Rose Garden

CONSENT CALENDAR
April 23, 2019

CONTACT PERSON

Scott Ferris, Director, Parks, Recreation & Waterfront, 981-6700.

Attachments:

1: Resolution

Exhibit A: Letter from Friends of the Berkeley Rose Garden

RESOLUTION NO. ##,###-N.S.

DONATION: INFORMATIONAL DISPLAY CASE FROM THE FRIENDS OF THE
BERKELEY ROSE GARDEN

WHEREAS, the City's Open Governance Ordinance (OGO) requires City Council disclosure and approval of any gift to the City in excess of \$1,000 (BMC Section 2.06.150, Ord. 7,166-N.S.); and

WHEREAS, the Friends of the Berkeley Rose Garden have purchased a redwood information display case that was designed and constructed by Berkeley Mills Furniture and Cabinetry for the cost of \$7,429; and

WHEREAS, the case will enable historic information and notices of activities to be posted in an attractive manner consistent with the aesthetics of the Berkeley Rose Garden; and

WHEREAS, the Friends were able to make this offer thanks to donations from throughout the community from those who love the Garden, one of the City's civic treasures.

NOW THEREFORE, BE IT RESOLVED by the Council of the City of Berkeley that the donation of an information display case valued at \$7,429 from the Friends of the Berkeley Rose Garden (Exhibit A) is hereby accepted.

Attachments:

Exhibit A: from Friends of the Berkeley Rose Garden



March 7, 2019

Mayor Arreguin & Members of the Berkeley City Council
City of Berkeley
2180 Milvia Street
Berkeley, CA 94707

cc: Scott Ferris
Director of Parks, Recreation & Waterfront
& Miguel Cortes, Rosarian

Subject: Offer to donate an information display case/kiosk for the Berkeley Rose Garden to the City of Berkeley

Dear Mayor Arreguin and Members of the City Council,

Friends of the Berkeley Rose Garden, a volunteer group committed to the celebration, support and enhancement of our City's wonderful Municipal Rose Garden, is pleased to offer to donate to the City of Berkeley a redwood information display case ("kiosk") designed and being constructed by Berkeley Mills.

The kiosk will enable historic information and notices of activities to be posted in an attractive manner consistent with the aesthetic of the Garden.

A drawing of the kiosk is attached. We have coordinated with Scott Ferris in its design. The City Department of Parks and Recreation will determine where to site it. Berkeley Mills generously gave us a discount of \$1000. The Friends will pay the attached invoice for \$6800 plus \$629 tax for a total of \$7429.

We are able to make this offer thanks to donations from throughout the community from those who love the Garden, one of our civic treasures.

We appreciate the City's ongoing commitment to the restoration of the Garden.

Sincerely,

A handwritten signature in black ink, appearing to read "C. B. Leland". The signature is fluid and cursive.

Catherine "Kit" Leland
For Friends of the Berkeley Rose Garden

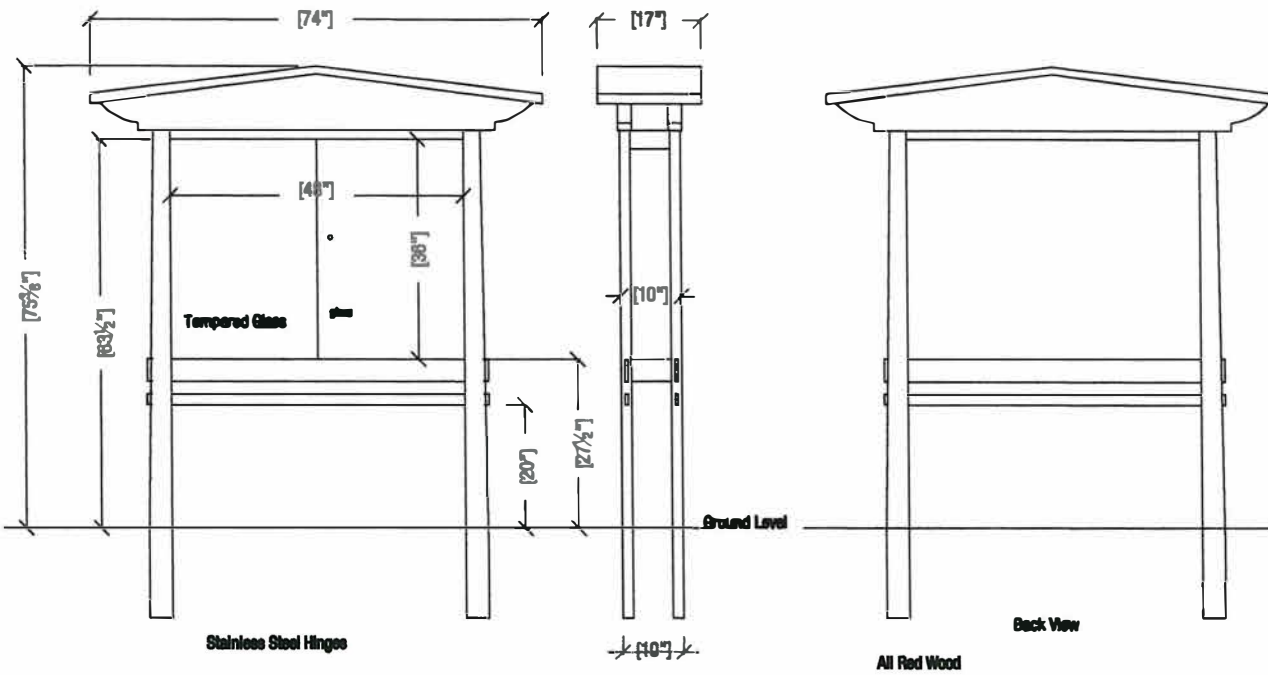

CLIENT	High Street
PROJECT	BENCH
DATE QUOTE #	00000001
DATE DRAW	04/20/2010
FILE	LAND CONSTRUCTION.DWG
SCALE	1"=4'-0"

COMPONENT	QUANTITY
FRAME	
ROOF PANELS	
SEAT PANELS	
BACK PANEL	
BRACES	
BLAY	
GLASS	
OTHER	

NOTES:
RED WOOD

APPROVED FOR CONSTRUCTION (DATE)	DATE
APPROVED FOR ARCHITECTURAL REVIEW (DATE)	DATE

TERMS AND CONDITIONS
All designs © 2010 Berkeley Mills & Furniture Co., Inc. Drawings remain the property of B Mills. They may not be copied, reprinted or distributed to others for any reason by any method without express written approval from Berkeley Mills. Customers will be liable for changes in bid, cost and damages resulting from breach of this provision. If the design project is not purchased by Berkeley Mills, all designs and drawings provided must be returned within 10 days.

Berkeley Mills
outdoor furniture design
3000 7TH STREET BERKELEY CA 94710
TEL. 916.842.2004 | FAX 916.842.0000

11

BERKELEY MILLS & FURNITURE CO., INC. 3000 7TH STREET BERKELEY, CA 94710
 TEL: 916.842.2004 FAX: 916.842.0000

