



Public Works - Transportation

01b
Special Meeting Item

ACTION CALENDAR
 November 12, 2019

To: Traffic Circle Task Force
 From: Farid Javandel, Transportation Manager, Public Works
 Subject: Technical Memo on Traffic Circle Planting Policies

INTRODUCTION

The purpose of this technical memorandum is not to take a position on what to do with existing trees in traffic circles, but to summarize from a traffic engineering and safety perspective, some of the considerations associated with vegetation in traffic circles. The Council appointed Traffic Circle Task Force has done substantial research and documentation on the important environmental and biodiversity benefits of trees and other vegetation in the City of Berkeley. Since that information has been thoroughly covered in the Task Force report and is outside the professional expertise of Traffic Engineering, it is not addressed in this technical memorandum, which instead focuses on the following:

1. Summarize existing City policies regarding traffic circles;
2. Provide a definition of sight lines in the context of traffic circles;
3. Briefly summarize traffic circle design and vegetation policies from other cities and agencies;
4. Identify additional traffic calming treatments with potential for significant vegetation that does not impact critical sight lines, or which enhances effectiveness of existing traffic circles. These represent options available to the City for future traffic calming projects or modifications to existing traffic circles if requested by the City Council.

1) EXISTING POLICY ON TRAFFIC CIRCLES

Neighborhood traffic circles are traffic calming devices installed in existing intersections to reduce speeds on streets without stop signs and reduce the number of potential traffic flow conflicts within the intersection regardless of other traffic controls at the intersection. A traffic circle controls speed primarily by changing the straight-line path of travel through an intersection into a curved path of travel that can only be followed at a lower speed. Secondly the presence of a circle and any vegetation or signs in an intersection may break up the perception of a long open and uninterrupted stretch of roadway that might seem inviting to faster driving.

There are many factors that must be balanced in order for a traffic circle to slow traffic but still allow passage of larger vehicles like fire engines and refuse collection trucks while leaving safe setbacks between the circle and crosswalks. Existing City policies are intended to provide general guidelines for traffic circle designs that will meet these needs but may need to be refined based on needs of a specific location. City of Berkeley policies on traffic circles include the standard plans for design of the circle as shown in Attachment 1; the 2012 policy on appropriate vegetation in traffic circles and maintenance by neighborhood volunteers as documented in Attachment 2; and an unwritten policy on appropriate dimensions for trees in circles to minimize the potential for inappropriate visibility obstructions based on the Traffic Engineering industry standards of practice for sight lines at intersections.

Berkeley's standard plans for Traffic circles in Attachment 1 are based on similar plans from other Cities such as Seattle. Key elements include mountable curbs to accommodate large vehicles while controlling speed of smaller vehicles, reflectors and signs for visibility, minimum desired setback distances to crosswalks and curbs, and low-cost curb and pavement markings on approach roadways.

The Traffic Circle Planting Policy (attachment 2) established in 2012, documented and clarified existing practices with respect to visibility and maintenance associated with neighborhood installed ground cover vegetation in traffic circles. Specifically, it specified that "to preserve adequate visibility, there shall be no vegetation that exceeds two feet in height as measured from the top of the curb on the island. Any vegetation exceeding this height shall be removed or cut back below two feet within two weeks of notice by the City." The policy further recommended a list of plants identified by Landscape Maintenance staff as not expected to exceed the two-foot height limit. However, this is not intended to be an exhaustive nor exclusive list and can be amended as other appropriate plants are identified. Accordingly, exceptions have been made when requested to allow additional plants that can comply with the height limits. Residents making these requests have been reminded that while exceptions to the plant list can be made, the vegetation must still comply with the height limit or be removed either by residents or the City.

Some residents maintaining traffic circles have also requested to be allowed to plant trees in new traffic circles. These residents have been told that although the written Traffic Circle Planting Policy does not address trees, it may be acceptable to plant trees with slender trunks and with a canopy that does not extend below seven feet high. One neighborhood asked if they were permitted to plant a tree similar to the one at the intersection of Ordway and Posen in Albany, and were told that such a tree could be compliant with the visibility requirements if well maintained.



Figure 1 Tree in traffic Circle at Ordway/Posen

2) DEFINITION OF SIGHT LINES AT A TRAFFIC CIRCLE

There are two types of sight lines to be considered at a traffic circle. The first is a vertical sight line, which can be considered the ability of a driver to see over an obstacle in order to observe an object or person in the road. In the context of a traffic circle, this means the ability of a driver to see over ground cover vegetation in a circle and observe an object, animal, or person who may have fallen on the far side of the circle. For the purposes of determining the appropriate vegetation height, it is assumed that the driver eye height is approximately four feet above the pavement and that the object they need to see is no more than two feet high, representing a two-foot difference in height. If the object to be seen is 60' from the driver and the far side of the circle is 45' from the driver (three quarters of the distance), then the ground cover must be at least three quarters of the height difference lower than the drivers eye height. This means the vegetation would have to be one and a half feet lower than the driver's eye, which equates to two and a half feet above the pavement or two feet above the top of a six-inch curb, as specified in the City's existing Traffic Circle Planting Policy.

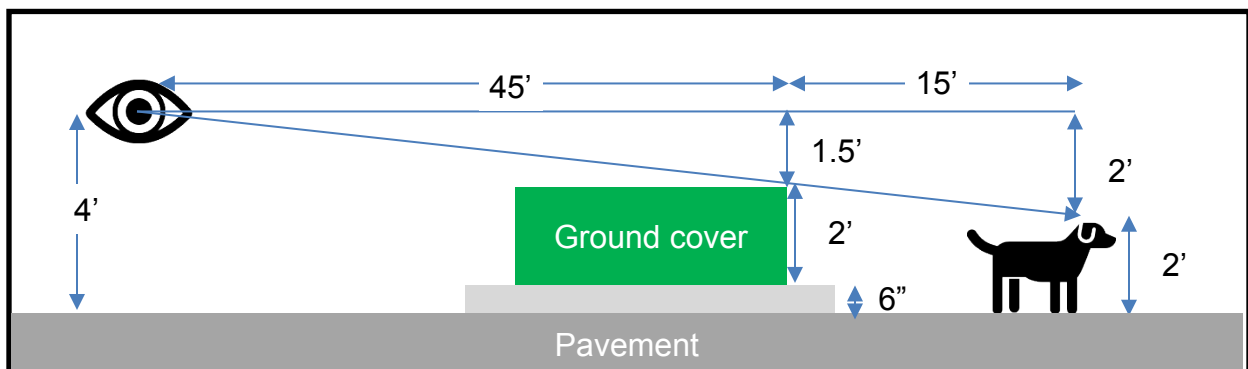

Figure 2 Vertical sight line measurement

The horizontal sight line at a traffic circle is the one that relates to trees. Because a tree trunk is a continuous vertical obstruction, it creates a vertical blind spot on the far side of the intersection from a driver. The width of the blind spot is proportional to the width of the tree and the distance from the driver to the tree and to the far crosswalk where a person may be walking. The image below illustrates the view from above and typical dimensions in order to calculate that a tree trunk over six inches wide has the potential to obscure the ten-inch width of an adult standing in profile in the far crosswalk.

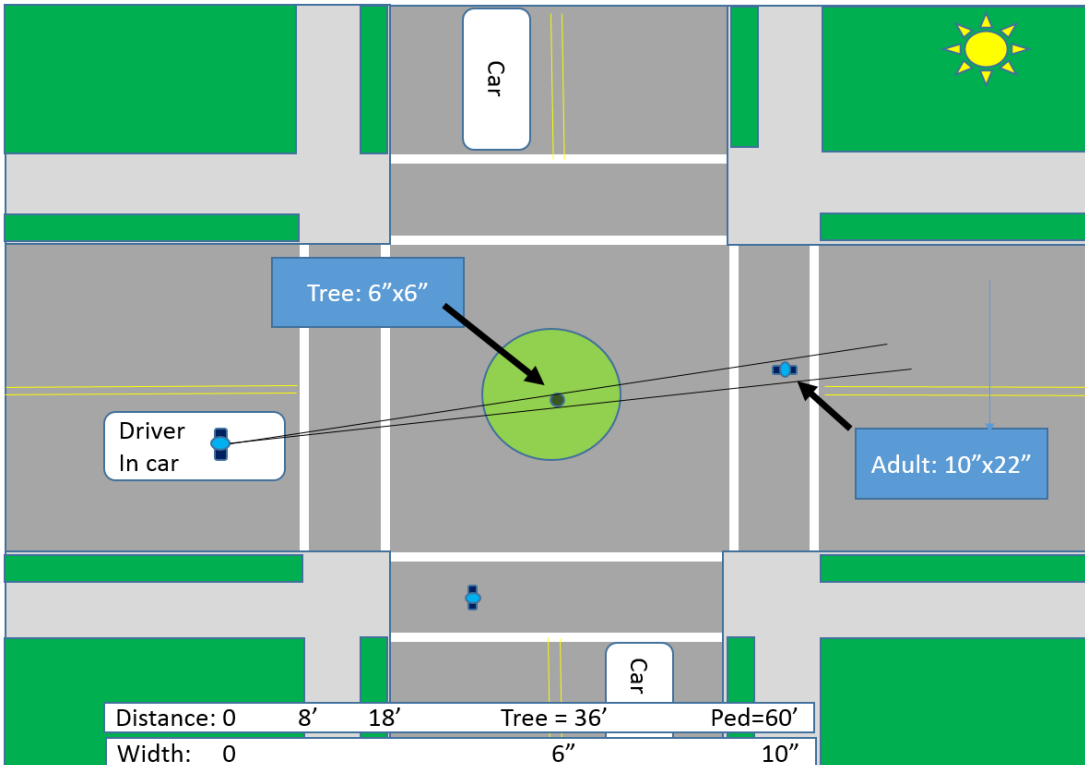

Figure 3 Horizontal sight line measurement

The preceding image illustrates not only the relative position of the driver and pedestrian, but the fact that there may be other cars and pedestrians present at the intersection, and that there may also be lighting or glare issues related to location of the sun relative to the driver. As a result of these factors, a driver glancing across the intersection and not seeing a pedestrian behind the tree, may then turn their full attention to the cross traffic that may or may not enter the intersection before them and another pedestrian who may be close to their path of travel as they go around the circle. The angle of the sun may also make it harder to notice the pedestrian who may have walked forward into the potential point of conflict. To ensure safety one should not assume that a driver will continuously scan the entire intersection or that they would even try once their quick glance that did not reveal a pedestrian has convinced them that there is no pedestrian and they need not look any more.

To establish the maximum size of an object that obstructs horizontal sight lines, a traffic engineer or other decision maker must decide how big a blind spot is acceptable given that a driver dealing with other distractions at the intersection may only look in the direction of the blind spot once. Traffic Engineering staff does not recommend creating any new blind spots large enough to hide a pedestrian, so any new trees over six to eight inches in diameter should be planted somewhere other than in a traffic circle.

3) TRAFFIC CIRCLE POLICIES OF OTHER AGENCIES

There are many and varied sources of information and complex criteria on when to use traffic circles, how to design them, and the role of vegetation in the circles. City Traffic Engineering staff have based our policies and designs on professional training, existing policies from other cities and agencies, decades of professional traffic engineering experience both in Berkeley and other cities, consultation with engineers, planners, landscape architects, and other experts, and specific conditions at each traffic circle location. Some of what Berkeley does with traffic circles is very similar to other Cities and some is different. In order to provide some continuity with the research done by the Traffic Circle Task Force, Traffic Engineering staff has reviewed the traffic circle examples shown in the source materials listed by the Task Force and provides some observations on those examples from the perspective of a professional traffic engineer. To avoid selection bias, we have tried to show all photos of traffic circles from the reports or web sites referenced by the Task Force along with a brief commentary on each.

Reference 1: Lupfer, Patrick. "Neighborhood Traffic Circles - Intersection of South Street and Intervale Road in Brookline, MA" (Calm Streets Boston, April 24, 2012)



Figure 4 Neighborhood Traffic Circle with Landscaping in Vancouver, Canada (<http://www.cstreetne.blogspot.com>)

Notes: This circle at an uncontrolled intersection (no stop signs) features a mountable concrete apron, simple directional signs, low ground cover, a slender tree with minimal visual impact, no reflectors, and no crosswalks.

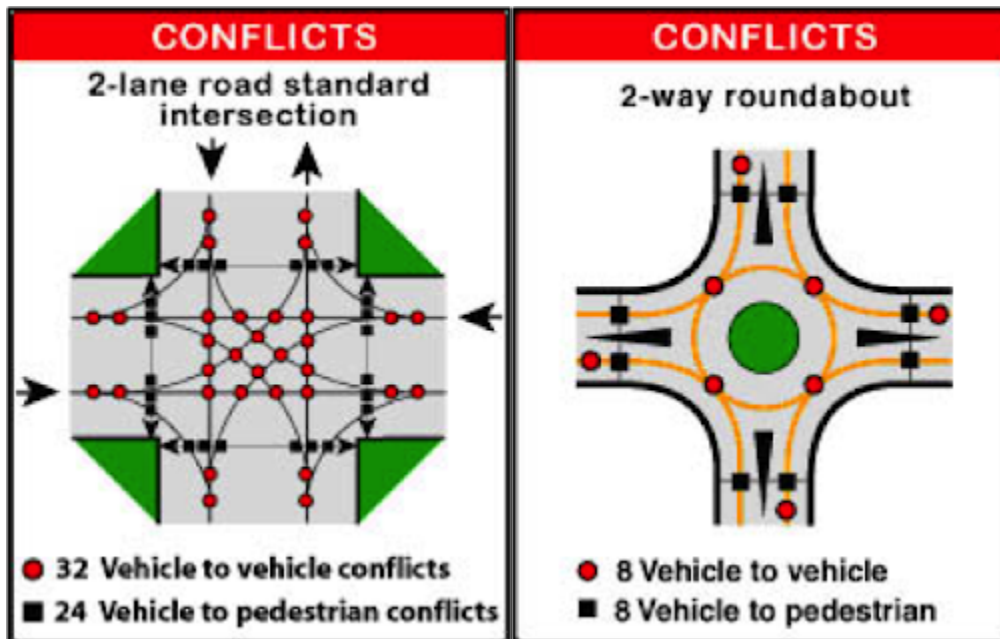

Figure 5 Traditional Intersection Conflict Points compared to Modern Day Roundabout Conflict Points (<http://www.wcroads.com>)

Notes: Figure 5 shows a roundabout, not a traffic circle. There are no true roundabouts in Berkeley. A roundabout features raised islands on the approach to the intersection that serve to slow traffic before the intersection and provide a pedestrian refuge in the middle of each crosswalk so that pedestrians only need to cross one direction of traffic at a time. Additionally, crosswalks at a roundabout are set back at least one car length from the intersection so that motorists' attention at the crosswalk can be exclusively on pedestrians, and when entering the roundabout their attention can be exclusively on vehicles in the roundabout because of the significant separation of these conflict points. At traffic circles the crosswalk is immediately adjacent to the traffic circulating in the circle, so there is no effective separation of conflict points, and with no splitter island there is no pedestrian refuge. These are significant differences between roundabouts and traffic circles, which in turn change how visibility considerations are incorporated into the design. Proper roundabouts are much larger than traffic circles in order to create adequate space and travel time at controlled speeds between conflict points so that only the immediate conflict point needs good visibility. The article from which this image was taken does go on to describe the basic difference between a Neighborhood Traffic Circle and a Modern Day Roundabout but does not elaborate on the different sight distance considerations.



Figure 6 Traffic Circle with Scraped Curb from Heavy Vehicle Traffic

Notes: This image is used to illustrate curbs scraped by large vehicles. It features a single sign post with reflectors facing all four directions, no stop signs, no crosswalks or curb ramps, low ground cover, no trees, and has curb extensions on the far corner of the intersection to significantly reduce vehicle speed and pedestrian crossing distance.



Figure 7 Neighborhood Traffic Circle at South Street and Intervale Road, Brookline, MA

Notes: This Circle features directional and reflector signs in all directions, a mountable curb with reflective markers, a painted edge line, low ground cover, no trees, well marked crosswalks, curb extensions to narrow traffic lanes and slow traffic, no parking on all approaches to improve visibility, stop signs with advance stop bars on two approaches and yield signs on two approaches. Videos on the web site illustrate that cars slow down significantly on the approaches and pedestrians across the intersection are easily visible the entire time they are crossing.

Reference 2: Marek, John. "Neighborhood Mini Traffic Circles: Seattle Washington" a case study of Countermeasures on the webpages BIKESAFE (pedbikesafe.org)



Figure 8 This traffic circle in a Seattle neighborhood also incorporates stamped concrete.

Notes: This Circle features a single post with reflector signs in all directions, a two-foot wide stamped concrete curb with reflective markers, low ground cover, a single slender tree, no crosswalks or curb ramps, and no stop signs. This is one of 1,200 traffic circles in Seattle and was chosen by their Neighborhood Traffic Control Program Engineer to illustrate their traffic circle program.

Seattle uses traffic circles primarily in uncontrolled intersections with yield signs, not stop signs. Berkeley and Seattle use almost identical traffic circle construction details as do many cities.

Reference 3: Neighborhood Traffic Management Plan (City of Madison WI, 2004)



Figure 9 Traffic Circle - South Shore at Emerald, Madison WI

Notes: This circle features a mountable concrete curb, a single post with reflective signs in all directions, relatively low ground cover, and no trees.



Figure 10 Madison's first neighborhood traffic circle was installed in 1997 at Kendall and Grand Avenues.

Notes: This circle features a mountable concrete curb, a single post with reflective signs in all directions, 2-way stop, two crosswalks, low ground cover, and no trees.



Figure 11 testing of traffic circles for large vehicles

Notes: In these images, two proposed circle layouts are being tested with cones. The other shows a school bus just able to slowly pass an existing circle with mountable concrete curb, a single post with reflective signs in all directions, low ground cover, and no trees.

Reference 4: Traffic Calming ePrimer – Module 3 section 3.7 (U.S. Department of Transportation/Federal Highway Administration)

Notes: This document says that “A traffic circle can simply be a painted area, but it is most effective when it is defined by a raised curb and landscaped to further reduce the open feel of a street. A traffic circle can be landscaped with ground cover, flowers, and street trees. **Figures 3.7.1 and 3.7.2 illustrate two extremes in the amount of traffic circle landscaping.**” (emphasis added)

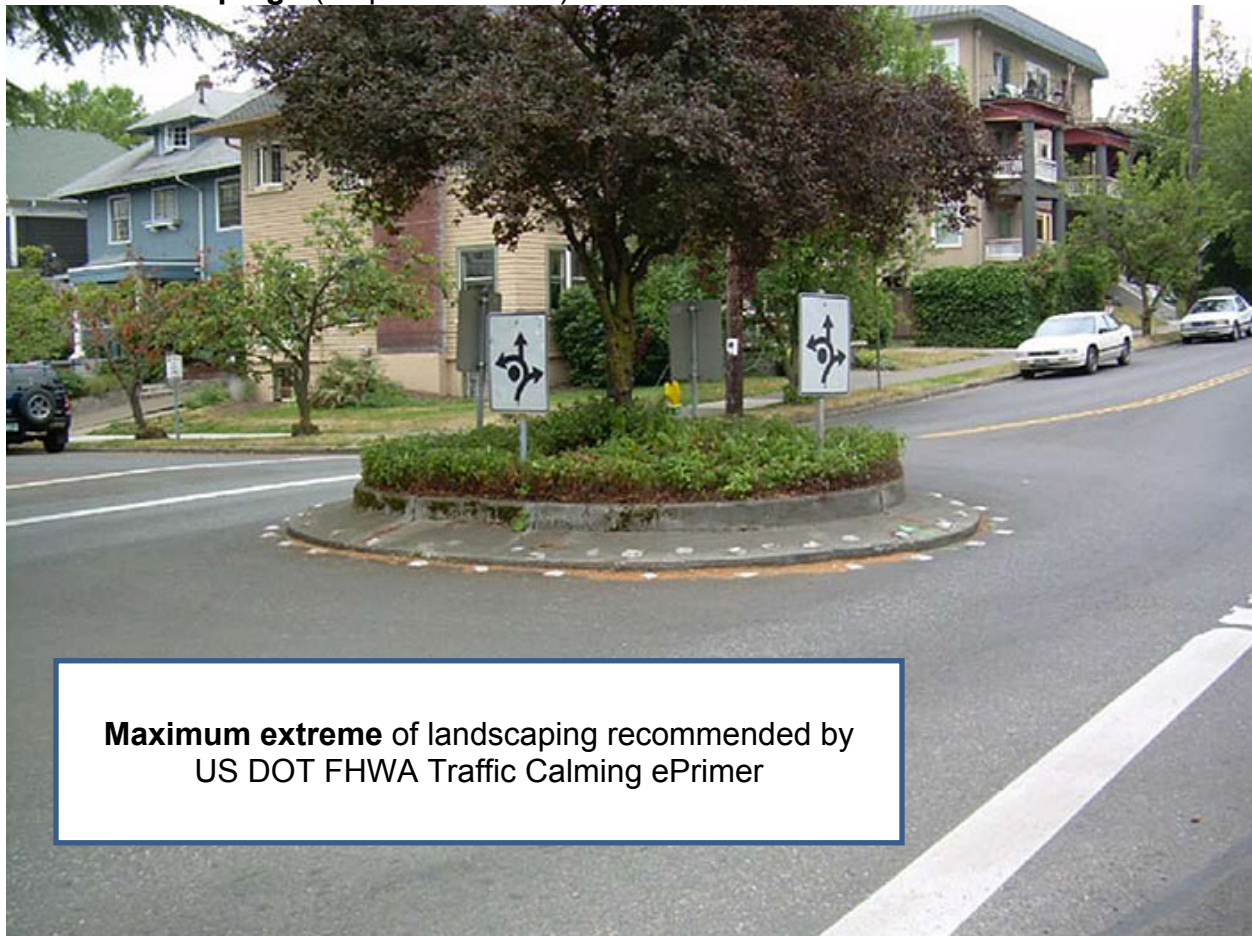

Figure 12 Landscaped Traffic Circle (Figure 3.7.1 of the Traffic Calming ePrimer)

Note: This figure (3.7.1) is one of the two figures which the US Department of Transportation Federal Highway Administration Traffic Calming ePrimer describes as illustrating “two extremes in the amount of traffic circle landscaping.” Since the other figure (3.7.2) depicts a circle with no landscaping, the above image represents that maximum extreme for the amount of landscaping in a traffic circle. This circle features a mountable concrete apron, guide signs facing all approaches, reflective markers on the apron and surrounding pavement, low ground cover, and a slender tree with the canopy pruned up to above driver eye height.



Minimum extreme of landscaping recommended by US DOT FHWA Traffic Calming ePrimer

Figure 13 Traffic Circle without Landscaping

Note: This figure (3.7.2) is the second of two figures which the US Department of Transportation Federal Highway Administration Traffic Calming ePrimer describes as illustrating “two extremes in the amount of traffic circle landscaping.” This circle with no landscaping represents that minimum extreme for the amount of landscaping in a traffic circle. This circle features a mountable concrete apron, guide signs facing all approaches, reflective markers around the apron, no stop signs or painted crosswalks, no visible vegetation, and no tree.



Figure 14 Traffic Circle in commercial setting. Brick pavers, stop signs, and curb extensions serve to slow traffic, reduce pedestrian exposure to vehicles, and maintain visibility. There are no plants on the circle, and no crosswalks. ADA ramps are directly into the path of circulating vehicles, so this may not be an optimal design.



Figure 15 Traffic circle in residential setting, with wide mountable curb, guide signs, yield control on approaches



Figure 16 Potential Pedestrian-Vehicle conflict at traffic circle because the circle is too close to the crosswalk



Figure 17 Bicyclist passing through traffic circle with mountable curb, low ground cover, low directional signs, tall and slender trees, painted splitter islands, no stop signs, and one visible crosswalk set back from the circle.

Reference 5: SFBetter Streets: A guide to making street improvements in San Francisco (City and County of San Francisco 2015)



Figure 18 Traffic Circle images from SF Better Streets web page

Notes: Both traffic circle images on the SF Better Streets web page show circles with simple curbs, reflective pavement markers, graphic guide signs facing each approach, marked crosswalks, low groundcover, and small trees that offer little visual obstruction. We requested additional city tree planting guidelines for traffic circles from the City of Madison, WI, the City of Seattle, WA; and the City of Brookline, MA, but have not heard back from these cities yet. So far only one staff member from San Francisco emailed to say the City and County of San Francisco, *generally, does not allow any plantings higher than low shrubbery and vines in order to maintain visibility through intersections.*

Reference 6: Urban Street Design Guide (National Association of City Transportation Officials 2013)



Figure 19 Conceptual rendering of a neighborhood traffic circle in NACTO's Urban Street Design Guide.



Figure 20 Image of a neighborhood traffic circle in the NACTO Urban Street Design Guide featuring low ground cover and no trees. This image was also used in Reference 1.



Figure 21 Image of a neighborhood traffic circle in the NACTO Urban Street Design Guide featuring low ground cover and no trees. This image was also used in Reference 1.



Figure 22 Image of a neighborhood traffic circle in the NACTO Urban Street Design Guide featuring low ground cover and no trees.



Figure 23 Image of a neighborhood traffic circle in the NACTO Urban Street Design Guide featuring mostly low ground cover and a small tree



Figure 24 Image of a neighborhood traffic circle in the NACTO Urban Street Design Guide featuring low ground cover and no trees.



Figure 25 Image of a neighborhood traffic circle in the NACTO Urban Street Design Guide featuring an oval shape, low ground cover, and no trees.



Figure 26 Image of a neighborhood traffic circle in the NACTO Urban Street Design Guide featuring painted splitter islands, low ground cover, and no trees.



Figure 27 This is more of a roundabout than a neighborhood traffic circle. It features a mountable apron, directional signs, low ground cover, and a small tree.



Figure 28 A fully mountable traffic circle in Baltimore, MD, with no signs or planting in the intersection.

The NACTO Design Guide indicates that shrubs or trees in the roundabout further the traffic calming effect and beautify the street, but need to be properly maintained so they do not hinder visibility.

4) OTHER TRAFFIC CALMING DEVICES WITH OPPORTUNITY FOR TREES

Other traffic calming treatments such as midblock curb extensions to create chokers and chicanes offer an opportunity to plant larger trees and taller ground cover without compromising intersection sight lines.



Figure 29 NACTO recommends planting trees on curb extensions aligned to the parking lane to narrow the overall profile of the roadway and reduce traffic speed



Figure 30 Commercial street with midblock curb extensions featuring trees



Figure 31 Midblock vegetated pinchpoint on residential street in Portland Oregon



Figure 32 Chicanes with Trees on Milvia Bike Boulevard

ENVIRONMENTAL SUSTAINABILITY

Safer roads encourage more walking and biking which are the cleanest and healthiest modes of transportation, even compared to electric vehicles and transit. The City of Berkeley Bicycle Plan determined that 71 percent of Berkeley residents are interested but concerned with respect to using bikes as a means of transportation. This means they have an inclination towards bicycling, but are held back by concern over sharing the road with cars and prefer separated pathways or low traffic neighborhood streets with traffic calming. Minimizing visibility obstruction is an important element of safe and comfortable streets for people on bikes who are less visible and less protected than people in cars. Thus, traffic circles with good visibility can both slow traffic and minimize potential blind spots where drivers may lose sight of bikes or pedestrians. This supports walking and biking, which are necessary to meet our Climate Action Plan goal of reducing greenhouse gas emissions from transportation sources.

CONCLUSION

The decision on keeping or removing any existing trees in traffic circles is up to the City Council. Staff is not offering a position on the recommendations of the Traffic Circle Task Force, and we agree that trees in general offer many benefits to the community and environment. Staff review of the reference documents cited in the Task Force report finds the following:

- Many cities have traffic circle design standards similar or identical to those used in Berkeley with respect to construction of the circle. Planting policies vary in specificity, but generally allow for ground cover and trees provided that visibility is taken into consideration;
- NACTO states that “Shrubs or trees in the roundabout further the traffic calming effect and beautify the street, but need to be properly maintained so they do not hinder visibility”¹;
- The majority of traffic circles used as illustrations or examples in the reference documents include low ground cover and good visibility, but few include trees. The few examples with trees generally include small or slender trees with little impact on sight lines; and
- The US Department of Transportation Federal Highway Administration Traffic Calming ePrimer² provides two photographs described as illustrating “two extremes in the amount of traffic circle landscaping.” One features no visible vegetation, and the other, shown below, features low ground cover and a slender tree with the canopy above a driver’s sight line.

¹ Urban Street Design Guide (National Association of City Transportation Officials 2013)

² Traffic Calming ePrimer – Module 3 section 3.7 (U.S. Department of Transportation/Federal Highway Administration)

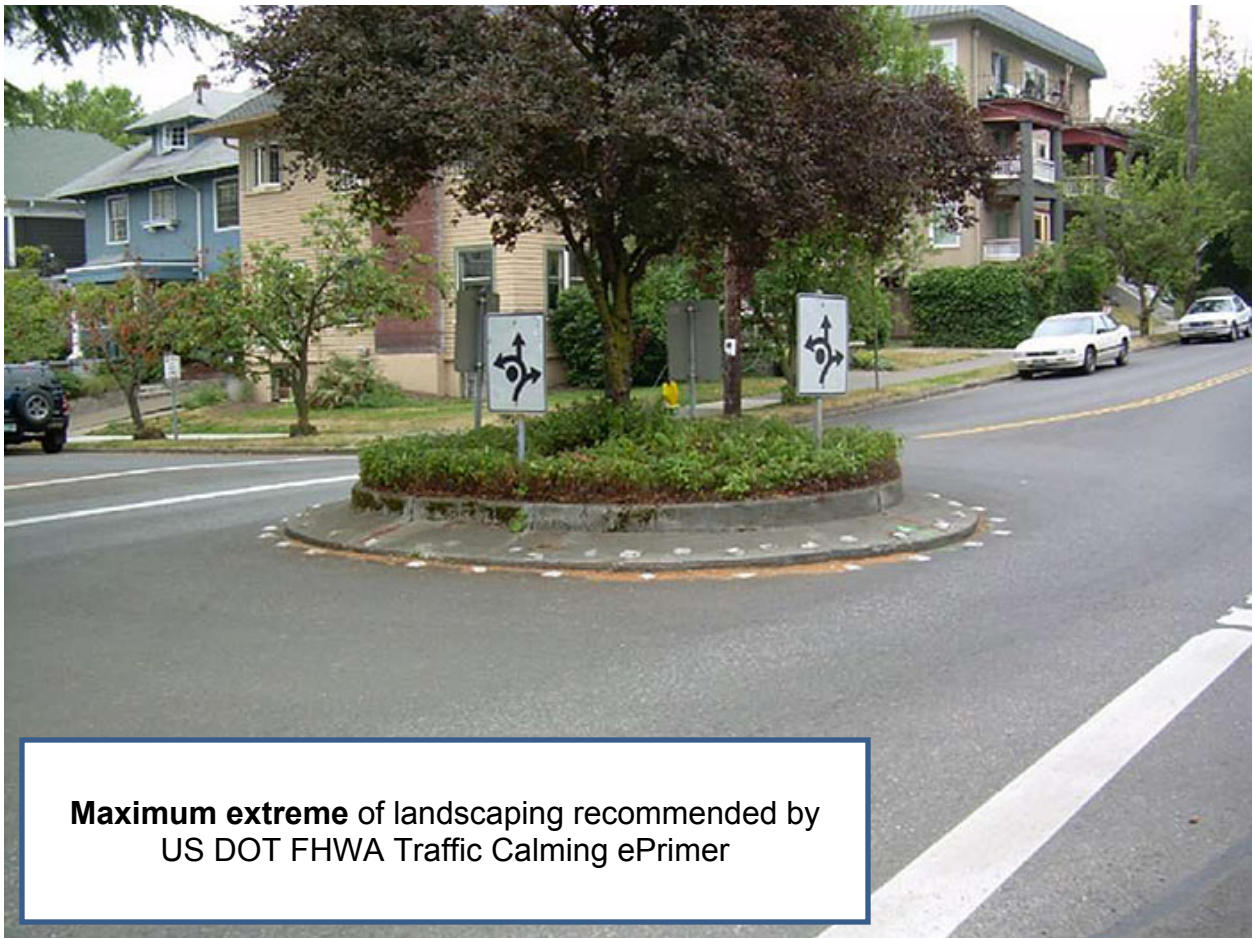

Maximum extreme of landscaping recommended by
US DOT FHWA Traffic Calming ePrimer

Figure 33 Photo from US DOT FHWA Traffic Calming ePrimer

Vision Zero is a Strategic Plan Priority Project to eliminate all fatal and severe traffic injuries in Berkeley by 2028, advancing our goal to create a resilient, safe, connected, and prepared city. Additionally, supporting active transportation through safe and comfortable roadways for cyclists and pedestrians helps Berkeley to be a global leader in addressing climate change, advancing environmental justice, and protecting the environment. Vision Zero principles require us to acknowledge that people make mistakes, and that our roads should be designed so that the consequence of such mistakes is not death or life altering injury.

Traffic Engineering staff recommend that to achieve reasonable visibility related safety for roadway users:

- The Traffic Circle Planting Policy be updated to explicitly state that plants other than those on the approved list may be used as ground cover in traffic circles so long as they grow or can regularly be maintained to not exceed the identified height limit of two feet above the top of curb of the circle;

- The Traffic Circle Standard Details should be updated to reflect the new shorter signs that have been installed in existing traffic circles in response to the Traffic Circle Task Force concern that taller signs might contribute to reduced sight lines;
- Any future trees planted for traffic calming purposes should be located in midblock curb extensions like chokers or chicanes rather than in traffic circles, so that they provide all the environmental benefits of trees without impacting sight lines at intersections. Note that this does not impact any existing trees;
- Whenever feasible trees in traffic circles should be maintained so that there are no branches below seven feet high; and
- No new trees should be planted in traffic circles until there is a way to ensure that the trunks or low branches will not grow wide enough to create a blind spot in which a pedestrian can be lost from sight.

Traffic Engineering staff notes that vegetated midblock curb extensions can be an appropriate place to plant multiple trees and taller ground cover or bushes without visibility restrictions, and that being in line with the existing roadway gutters, such vegetated curb extensions may also serve as bioswales for stormwater detention and filtration. Planting of trees in midblock curb extensions can be done any time that a neighborhood requests new traffic calming in conjunction with trees or tall plants that might impede visibility if placed at an intersection or as part of a three-to-one tree replacement mitigation if the City Council wishes to remove an existing tree from a traffic circle in the future. Other than updating the standard details with respect to signs, and clarifying flexibility of the plant palette in the Traffic Circle Planting Policy, staff is not proposing any policy change as part of this technical memorandum.

CONTACT PERSON

Farid Javandel, Transportation Manager, Public Works, 510-981-7061
Phillip L. Harrington, Director, Public Works, 510-981-6302

Attachments:

- 1: Existing Standard Plans for Traffic Circle Design
- 2: Existing (October 2012) Traffic Circle Planting Policy

Attachment 1 - Existing Standard plans for Traffic Circle Design

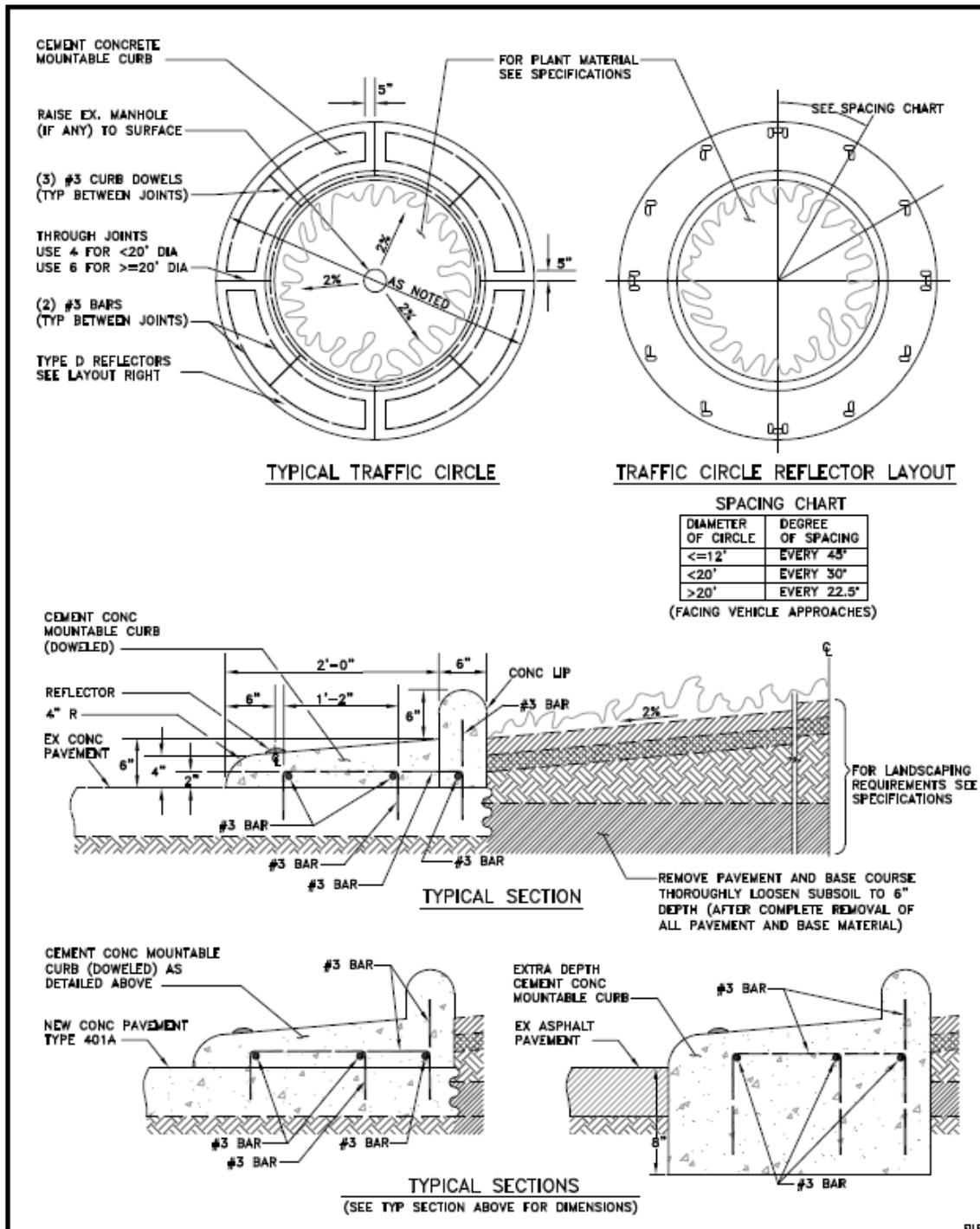

CITY OF BERKELEY DEPARTMENT OF PUBLIC WORKS		STANDARD DETAIL TRAFFIC CIRCLE	
SUBMITTED: _____	DATE: _____	DESIGN: HM	DATE: 4-18-14
SUPERVISING CIVIL ENGINEER _____	R.C.E. _____	DRAWN: ZT	SCALE: N.T.S.
APPROVED: _____	DATE: _____	CHECK: _____	BOOK: X
MANAGER OF ENGINEERING _____	EXP: _____		PLAN: X
			FILE: X

Error! No text of specified style in document.

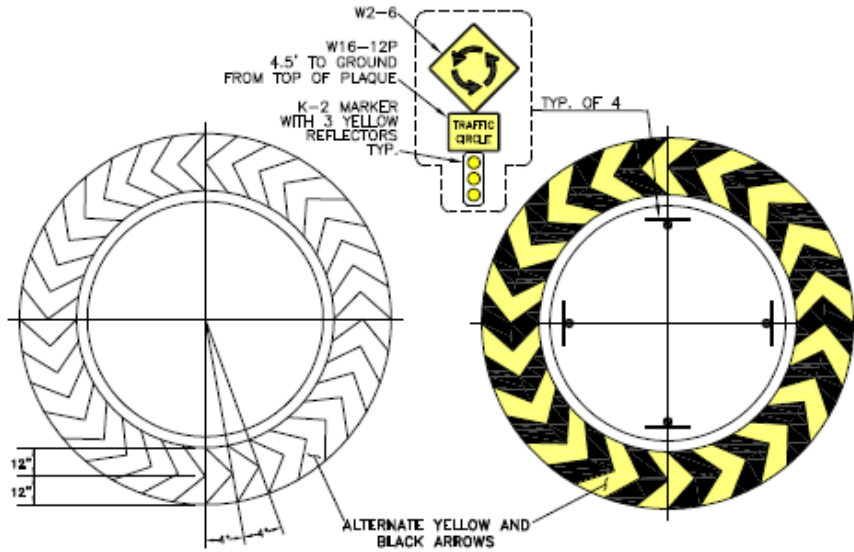

TRAFFIC CIRCLE SIGNING AND MARKING LAYOUT
(OPTION 1)

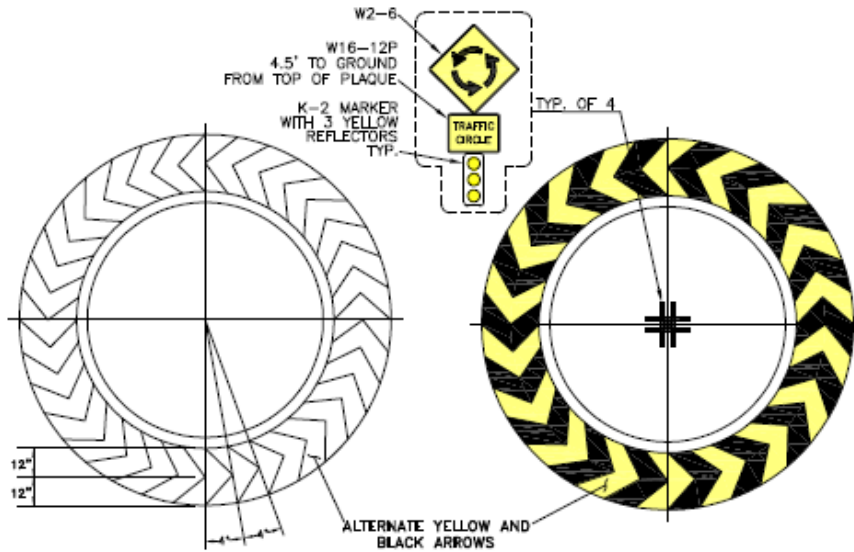

TRAFFIC CIRCLE SIGNING AND MARKING LAYOUT
(OPTION 2)

CITY OF BERKELEY DEPARTMENT OF PUBLIC WORKS		STANDARD DETAIL TRAFFIC CIRCLE	
SUBMITTED: _____	DATE: _____		
_____	R.C.E. _____		
SUPERVISING CIVIL ENGINEER	EXP. _____		
APPROVED: _____	DATE: _____	DESIGN: HM	DATE: 2-28-14
_____	R.C.E. _____	DRAWN: ZT	SCALE: N.T.S.
MANAGER OF ENGINEERING	EXP. _____	CHECK: _____	BOOK: X
			PLAN: X
			FILE: X

Error! No text of specified style in document.

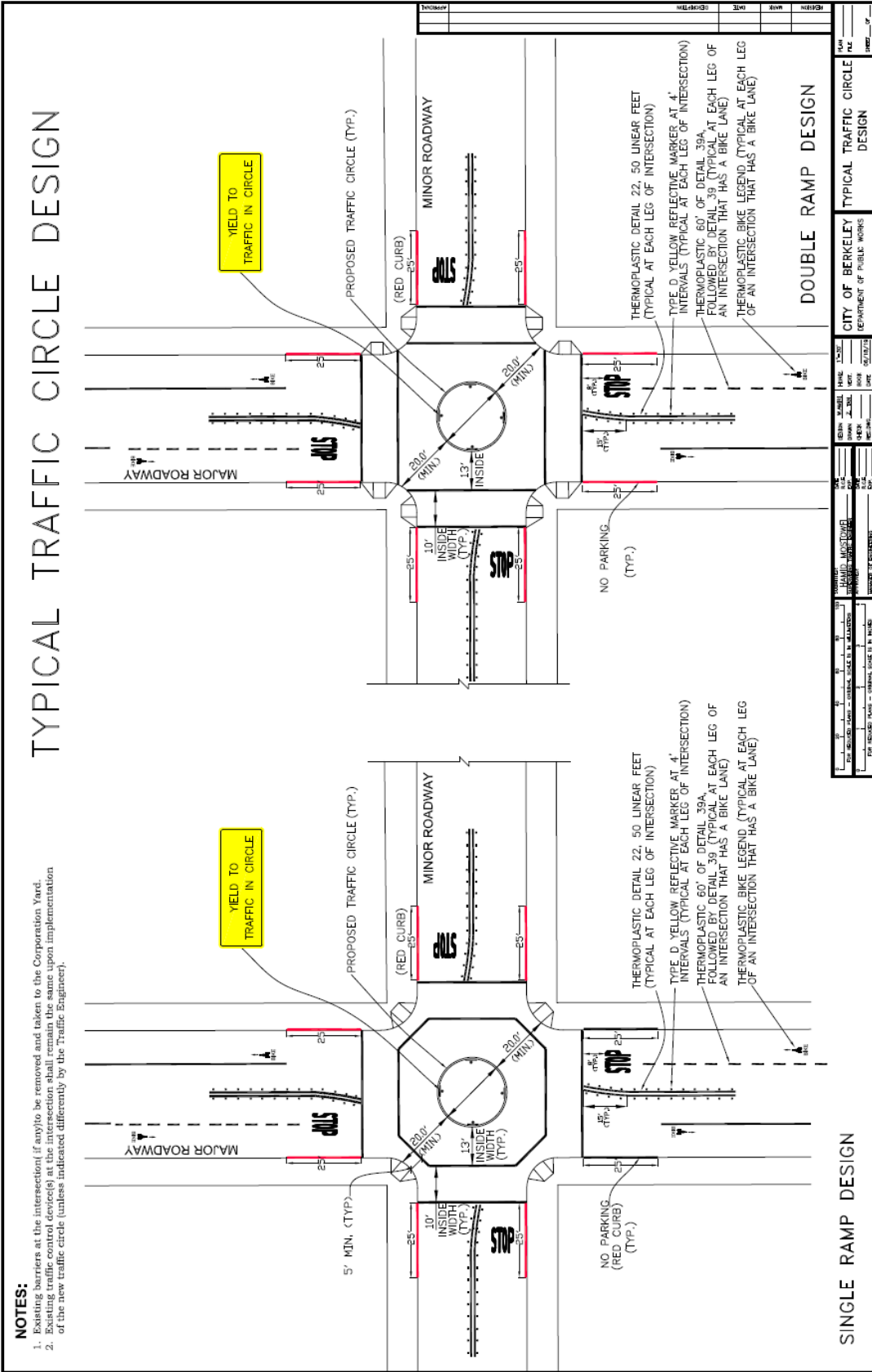



Public Works - Transportation Division
Oct 2012

Traffic Circle – Planting Policy

There are two main criteria used as the basis for what landscaping is permitted in traffic circles in the City of Berkeley. Foremost, the circles are and must continue to serve as a device to appropriately guide traffic. The planting and maintenance of traffic circles and traffic islands will be handled by neighborhood volunteers with oversight by Public Works Engineering and Traffic Divisions. Volunteer landscaping will be allowed based on the premise that it would not impact the limited resources for City staff. It is important to recognize that the primary purpose of traffic islands remains traffic control, and any beautification is incidental to and should not interfere with that purpose.

To serve as an appropriate device for guiding traffic the circles must not contain anything that would impede line of sight for and between vehicles and/or pedestrians, nor anything that would likely cause unnecessary harm to the occupants of a vehicle that might leave the road at these locations. The following criteria are to be used:

- A. To preserve adequate visibility, there shall be no vegetation that exceeds two feet in height as measured from the top of the curb on the island. Any vegetation exceeding this height shall be removed or cut back below two feet within two weeks of notice by the City.
- B. There shall be no boulders or other large/fixed object(s) with the intent or potential to abruptly stop the motion of a vehicle leaving the road and entering the traffic island.
- C. Objects to gradually slow the motion of a vehicle or absorb and dissipate the energy of a crash are acceptable, but only if specifically approved in advance by Traffic engineering staff and installed according to applicable standards and specifications. Such objects include crash barrels or guard rails with breakaway posts.

Volunteer installed and maintained landscaping will be allowed as follows:

1. Only plants from the approved list below may be planted or allowed to remain in traffic circles. The following plants were selected by Landscape Maintenance staff as appropriate for traffic circles and islands as they are not expected to exceed two feet in height:
 - a. #5 Ceanothus variety Anchor bay (height 18", 6' spread)
 - b. #8 Cotoneaster variety Adpressus praecox (height 18", 6' spread)

Error! No text of specified style in document.

- c. #18 Trailing lantana (height 24", 2-3' spread)
 - d. #25 Creeping rosemary (height 8 – 18", 4' spread)
 - e. #27 Black sage (height 12 – 24", 4 – 6' spread)
 - f. #28 Creeping sage (height 8 – 12", 3 -4' spread)
2. Planting and watering are the sole responsibility and expense of the neighborhood volunteers.
- a. The City has no budget to purchase plants for traffic circles. Neighborhood volunteers may purchase plants at their own expense from the list above.
 - b. There is no irrigation within the circles. Water may be delivered or supplied by hoses run from private properties. Any hoses may not cross traffic lanes and must be attended at all times.
3. Prior to any landscaping being installed a member of the public involved in that activity must be designated as the responsible contact person and added to the list maintained by Engineering Division staff. Contact information shall include name, address, phone number, and e-mail address (if available). An alternate contact person may also be provided.
- a. The designated contact person shall sign a document acknowledging the criteria under which the landscaping is being allowed and the rules for maintaining it.
 - b. Any noncompliance with the landscape maintenance policies established herein will be communicated to the designated contact person and/or their designated alternate if any.
 - c. Repeated failure to maintain landscaping according to the visibility requirements after proper notice to the designated contact person(s) may result in removal of the vegetation and replacement of the soil with hardscape materials at the discretion of the Public Works Department.
